

intra●se
SWEDMACH

YOUR MATERIAL HANDLING PARTNER
SINCE 1991

WORKSHOP EQUIPMENTS



WORKTABLES 5-12



PALLET LEGS 13



TOOL TROLLEYS 13-14



WORK SHOP TROLLEYS 15-16



TOOL CABINETS 17



TOOL PANELS & HOOKS 18-23



COMPUTER CABINETS 24-25

RACKS AND STORAGE



SHELVES 27



SHELVING SYSTEMS 28-29

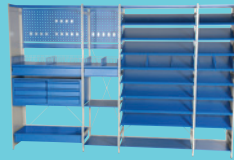

STEP STOOLS 30



STORAGE CABINETS 31-33



CHEMICAL CABINET 34



KEY BOXES 35



LOCKERS 35-39

TRANSPORT AND LIFTING



HAND TRUCKS 41-45



TROLLEYS 46-50

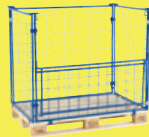

PALLET CAGES 51



TROLLEYS & TRANSPORT 52-55



PALLET TRUCKS 56-61



SCISSOR LIFTS 62-63



LIFTING TABLES 64-69



LIFTERS & STACKERS 70-78



ACCESSORIES, LIFTING, TRANSPORT 79-87

ENVIRONMENTAL HANDLING



DRUM LIFTERS 89-91



DRUM PALLETS 92-95



TOOL TROLLEY 96



BOTTOM DISCHARGING 97



REFUSE BINS 98



TILTING SKIPS 99-101



HEAVY DUTY TILTING SKIPS 102



SPECIAL TILTING SKIPS 103-105

OUTDOOR PRODUCTS

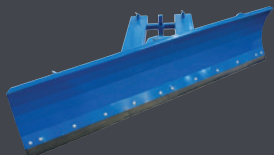

PLOUGHS 107-109

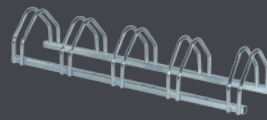
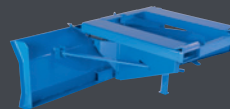

BICYCLE RACKS 110



SNOW SHOVEL 110



SALT & SAND CARRIER 110

Reservations:

- Due to printing technology reasons, shades of color may differ from reality.
- We reserve us against product- and design changes that can occur beyond our control.



Flat pack – Is good for the environment because of less transport space which also give you a lower transport cost and make them easier for storage before use.

Special products and product customization!

Can you not find what you are looking for? We have the ability to customize many of our products! We also know manufacturers all over the world so we can search for the products that will suit your need! Remember always to ask us first!



WORKSHOP EQUIPMENTS

WORKTABLE BASIC

Our new workplace series BASIC is now taken shape in cool fresh Scandinavian colors! The bright tabletop is easy to keep clean and gives a better overview of your work! With a capacity of 250 kg, it can handle the heavier work while giving a nice and professional expression! 35 mm thick table top of white laminate. With the accessories tabletop drawer, wall-hung panels and a smart shelf under the table, you can customize your workplace just the way it suits you the best! RAL 7038 Grey



Item No 4231082150



Item No 4035082011

SHELF FOR WORKTABLE BASIC

Item no.	Identification	Width mm	Depth mm
4035082011	For Basic 120	1070	450
4035082012	For Basic 150	1370	450
4035082013	For Basic 180	1670	450

Item no.	Identification	Width mm	Depth mm	Height mm
4231082120	Basic 120	1200	750	895
4231082150	Basic 150	1500	750	895
4231082180	Basic 180	1800	750	895



Item No 4035082014

Storage drawer for BASIC series. For installation underneath the table top. WxDxH mm: 450x450x150.

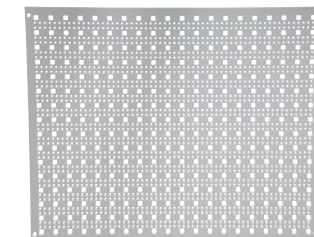

Item No 4038082016

Tool Panel for BASIC series. For installation on wall. WxHxD mm: 750x600x20. More info on page 14.



WORKTABLE STABLE

Worktable with manual height adjustment. Perfectly adapted for assembly work. 20 mm thick table top of light grey laminate. Maximum load of 150 kg evenly distributed over the surface of the table. - RAL Grey 7038.



Item No 4230074302

Item no.	Identification	Height adjustment	Width mm	Depth mm	Min. height mm	Max height mm
4230074302	Stable Worktable 16	Manual	1600	800	720	970
4230074304	Stable Worktable 20	Manual	2000	800	720	970



WORKTABLE ELECTRIC

Worktable electric height adjustment. Perfectly adapted for assembly work. 20 mm thick table top of light grey laminate. Maximum load of 150 kg evenly distributed over the surface of the table.
- RAL Grey 7038.



Item No 4230074303



With display that shows the height and a memory feature that allows you to save up to 4 different heights that you can easily return to with a touch of a button.

Item no.	Identification	Hight adjustment	Width mm	Depth mm	Min. height mm	Max height mm
4230074303	Electric Worktable 16	Electric	1600	800	620	1270
4230074305	Electric Worktable 20	Electric	2000	800	620	1270

WORKTABLE ELECTRIC STRONG

Worktable electric height adjustment. Perfectly adapted for assembly work. Supplied with a hard-wearing 42 mm thick table top in order to cope even with really heavy and dirty work. Maximum load of 300 kg evenly distributed over the surface of the table.
- RAL Grey 7038.

With display that shows the height and a memory feature that allows you to save up to 4 different heights that you can easily return to with a touch of a button.

Item No	Identification	Width mm	Depth mm
4231743311	Oil-tempered board	1600	800
4231743312	Oak board	1600	800
4231743313	Aluzink	1600	800
4231743314	Vinyl	1600	800
4231743315	Laminate	1600	800
4231743331	Oil-tempered board	2000	800
4231743332	Oak board	2000	800
4231743333	Aluzink	2000	800
4231743334	Vinyl	2000	800
4231743332	Laminate	2000	800



Item No 4231743312

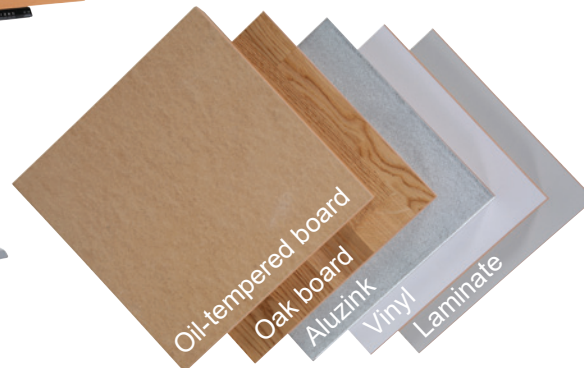

EXTRA STRONG WORKTABLES

Extra strong worktables for heavy handling with manual height adjustment of between 740 and 1100 mm. Supplied with a hard-wearing 42 mm thick table top in order to cope even with really heavy and dirty work.

Maximum load of 500 kg evenly distributed over the surface of the table. Supplied complete with trestles.

Suitable wheel set, item no 8612019080. Four rubber wheels 100x36mm with breaks.
- RAL Grey 7038.



Item No 4231743302

Item No	Identification	Width mm	Depth mm
4231743301	Oil-tempered board	1600	800
4231743302	Oak board	1600	800
4231743303	Aluzink	1600	800
4231743304	Vinyl	1600	800
4231743305	Laminate	1600	800
4231743321	Oil-tempered board	2000	800
4231743322	Oak board	2000	800
4231743323	Aluzink	2000	800
4231743324	Vinyl	2000	800
4231743325	Laminate	2000	800



EXTRA STRONG WORKTABLES

Extra strong worktables for heavy handling. Supplied with a hard-wearing 42 mm thick table top in order to cope even with really heavy and dirty work.

Height 900mm. Maximum load of 500 kg evenly distributed over the surface of the table.

The drawers are fitted with ball bearings and are 100% telescopic.

Supplied complete with a trestle, a drawer unit (Item No 4035074350) with 5 drawers 1x50, 2x100, 1x150 and 1x200 mm and a base panel. Capacity per drawer 40 kg.
- RAL Grey 7038 / Blue 5005.

Item No 4232743343



Item No	Identification	Width mm	Depth mm
4232743341	Oil-tempered board	1600	800
4232743342	Oak board	1600	800
4232743343	Aluzink	1600	800
4232743344	Vinyl	1600	800
4232743345	Laminate	1600	800
4232743351	Oil-tempered board	2000	800
4232743352	Oak board	2000	800
4232743353	Aluzink	2000	800
4232743354	Vinyl	2000	800
4232743355	Laminate	2000	800



EXTRA STRONG WORKTABLES

Extra strong worktables for heavy handling. .
Supplied with a hard-wearing 42 mm thick table top in order to cope even with really heavy and dirty work.

Height 900mm. Maximum load of 500 kg evenly distributed over the surface of the table.

The drawers are fitted with ball bearings and are 100% telescopic.

Supplied complete with a trestle, a drawer unit (Item No 4035074352) with 6 drawers and a base panel.

Drawer height: 6x100 mm. Capacity per drawer 40 kg. - RAL Blue 5005, Grey 7038.

Item No 4232743361



Item No	Identification	Width mm	Depth mm
4232743361	Oil-tempered board	1600	800
4232743362	Oak board	1600	800
4232743363	Aluzink	1600	800
4232743364	Vinyl	1600	800
4232743365	Laminate	1600	800
4232743381	Oil-tempered board	2000	800
4232743382	Oak board	2000	800
4232743383	Aluzink	2000	800
4232743384	Vinyl	2000	800
4232743385	Laminate	2000	800



STORAGE DRAWER

Storage drawer for installation underneath the table top of the worktable. Lockable, fitted with a cylinder lock and ball bearings and 100% telescopic. Capacity per drawer 40 kg. Drawer WxDxH = 535 x 665 x 100 mm. - RAL Blue 5005, Grey 7038.

Item No 4035074310



DRAWER ORGANISER

Drawer organiser for drawer units and storage drawers. RAL Blue 5005.

Item No	Length mm	Depth mm	Height mm
4035074313	444	418	90
4035074314	894	435	85
4035074315	457	340	37
4035074316	457	340	90
4035074317	445	600	40
4035074318	445	600	95

Item No 4035074314

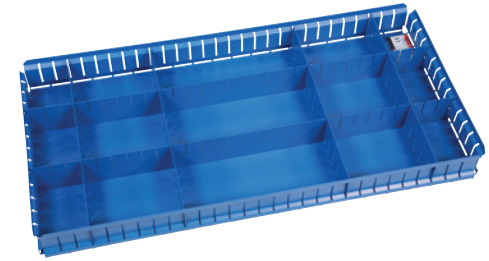

NEW

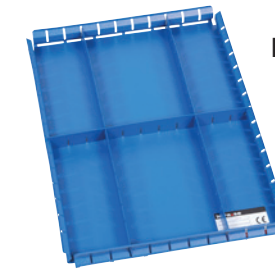

Item No 4035074315

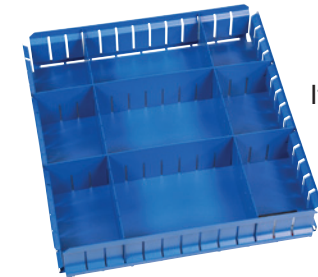

Item No 4035074313

DRAWER UNIT WITH A CENTRAL LOCK

The drawers are fitted with ball bearings and are 100 % telescopic. Capacity per drawer 40 kg.

Max load in the whole drawer unit = 170 kg.

- RAL Blue 5005, Grey 7038.

ACCESSORIES:

- Drawer unit top of sheet metal painted in grey = Item No. 4035074355

- Wheel set, 4 castors, 2 with brakes. = Item No 4035074356

- Rubber mat, black = Item No 8711074358

Item No	Identification	External dimensions: Width x Depth x Height	Internal dimensions: Width x Depth mm	Capacity in kg per drawer	Total capacity kg
4035074350	Drawer unit, 5 drawers	535x665x800 mm	450x606	40	170
4035074352	Drawer unit, 6 drawers	535x665x800 mm	450x606	40	170

Item No 4035074350



Item No 4035074352



Complete with
all accessories!

PACKING TABLE KIT

Suitable for worktable **4230074304** and **4230074305 (with accessory 4035074328)**

Cutting width 1,300 mm

NOTE: Table and packing material is not included.

- RAL Blue 5005, Grey 7038.



Item No 4035074324

ATTACHMENT KIT

This kit makes your worktable a complete workplace. The kit consists of:

- 3 perforated pillars.
- 2 struts, 645 or 875 mm.
- 2 perforated panels 666x480 mm or 886x480 mm.
- 2 shelves 666 or 886 mm.
- 1 Tray Bar, including 5 trays.
- 1 hook kit with 30 mixes hooks, (contents, see Item No 4038074113).

Item No 4035074320 is suitable for worktables with a width of 1600 mm.

Item No 4035074322 is suitable for worktables with a width of 2000 mm.

- RAL Blue 5005, Grey 7038.

Item No 4035074320

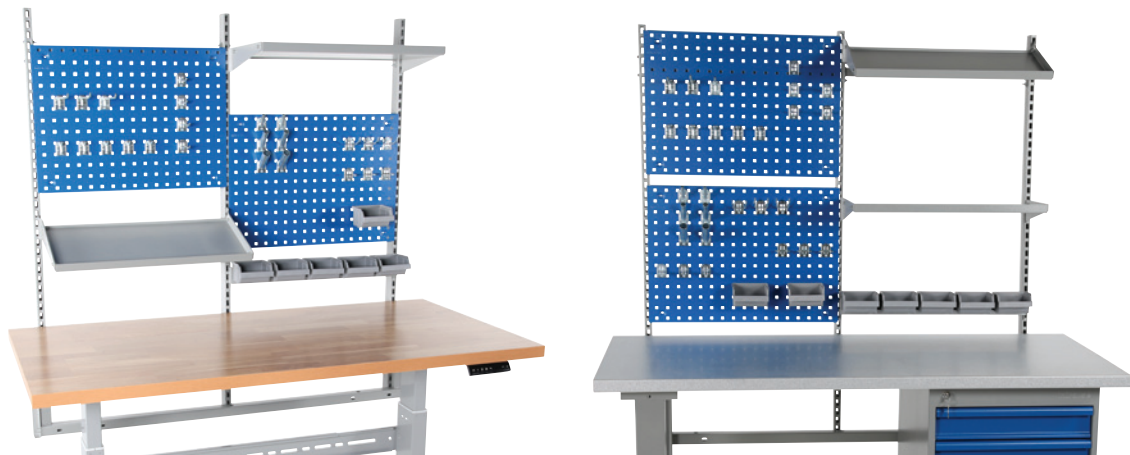

ACCESSORIES FOR WORK TABLES

Our new range of accessories for our attachment kits to workbenches. Make your work easier and more ergonomic with our wide selection.



Straight flexible arm + joint

Item No 4035081118



Flexible arm + joint

Item No 4035081119

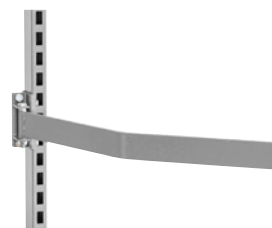

Flexible extension arm + joint

Item No 4035081120

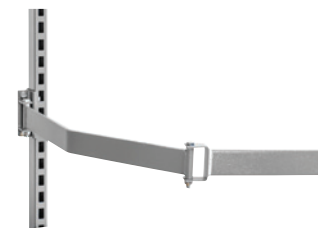

Screen holder for flexible arm

Item No 4035081121

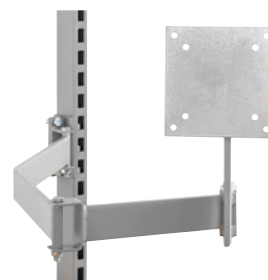

Tablet holder for flexible arm

Item No 4035081122



NEW

Screen + keyboard holder for flexible arm

Item No 4035081123

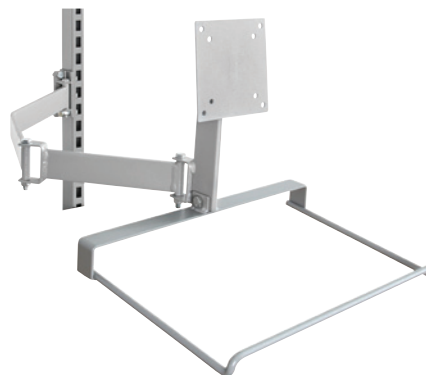

Document holder for flexible arm

Item No 4035081124



Plastic tray holder for flexible arm

Item No 4035081125

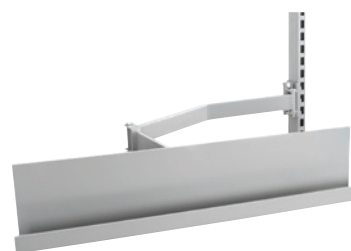

Shelf for flexible arm

Item No 4035081126

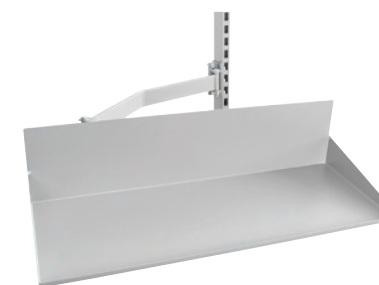

Tool panel for flexible arm

Item No 4035081127

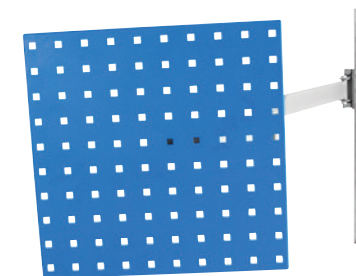

LED light, 475 mm wide



LED light, 870 mm wide



Item No 4035081113



NEW

Item No 4035081114



Support arm for workbench extension
Item No 4035081105



Suspension hook for workbench extension
Item No 4035081112



Suspension hook w. wheels for workbench extension
Item No 4035081115



Item No 4035081106



C-rail for workbench extension, 1590 mm

Item No 4035081107



C-rail for workbench extension, 1990 mm

PALLET LEGS

Table of opportunities! There are load pallets everywhere. You can fasten the pallet legs in 20 seconds and get a stable worktable, exhibition table or platform. Easy to move with a forklift truck or a stacker! The height is included the pallet!

The wheel set in size 125mm increase the total height with 155 mm.



COVER FOR PALLET LEGS

Item No	Color	LxWxH mm	Material
2181103920	Black	1200x800x150	PVC textile
2181103922	Green	1200x800x150	PVC textile
2181103923	Red	1200x800x150	PVC textile
2181103924	Yellow	1200x800x150	PVC textile
2181103925	White	1200x800x150	PVC textile
2181103926	Blue	1200x800x150	PVC textile
2181103927	Grey	1200x800x150	PVC textile

WHEELS FOR PALLET LEGS



Item No 8612019075

Item No 2541010850



Item No	2541010580	2541010730	2541010850
Identification	PB 580	PB 730	PB 850
Loading capacity kg	500	500	500
Height inc. pallet mm	580	730	850
Width mm	800	800	800
Material	Steel tube	Steel tube	Steel tube
Surface treatment	Zinc coating	Zinc coating	Zinc coating

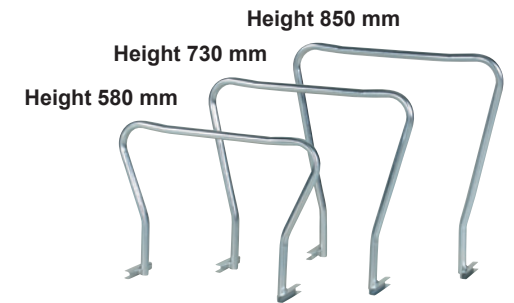

TOOL TROLLEY

The perforated panels have 9 mm square holes with cc 38 mm for hanging of tool hooks.
- RAL Blue 5005, Grey 7038.

Item No 4033074050

Item No	4033074050
Height mm	1660
Depth bottom mm	750
Depth top mm	220
Width mm	1000
Weight kg	60
Rubber wheels diameter mm	125
Capacity kg	400

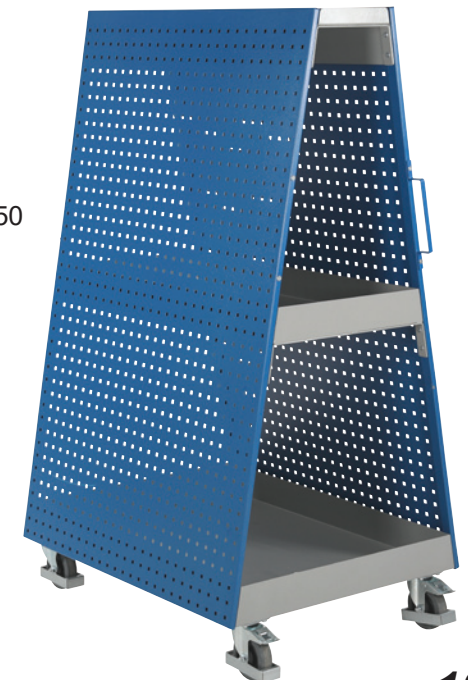

TOOL TROLLEYS

Our range of portable mobile tool trolleys/work benches contains two different models.

The mobile tool trolleys/work benches have a working surface and four strong wheels, two with brakes. The trolley can be equipped with an extension kit (Item No 4033074040).

Both trolleys are supplied with individual drawer restraints. The drawers are fitted with ball bearings and are 100% telescopic. Drawer height: 1x200, 4x100 (Item No 4033074020) Drawer height: 2x200, 8x100 (Item No 4033074030) - RAL Blue 5005, Grey 7038.

Item No 4033074030



The attachment kit consists of:
 - 2 perforated pillars
 - 1 perforated panel
 - Hanging strip with 7 plastic bins
 - 1 shelf
 - 1 pack of 20 mixed hooks ,
 (part no. 4038074112).

Item No 4033074020+4033074040



WORKSHOP TROLLEY

The workshop trolley has a stable design with a cabinet of perforated steel and undercarriage in square pipe. The trolley also has four swivel wheels, two with brakes.

Supplied with a kit of 20 mixed hooks (Item No 4038074112).
 Accessories: Drawer unit (Item No 4033074070)
 The drawers are fitted with ball bearings and are 100% telescopic. Drawer height: 1x50, 2x150, 1x250.

Capacity per drawer 40 kg.
 - RAL Blue 5005, Grey 7038.

Item No 4033074060+4033074070

Item No	Identification	Width mm	Depth mm	Height mm	Cabinet height x depth x width mm	Wheel Ø x width mm	Weight kg
4033074060	Workshop trolley	600	400	1800	885x400x600	125x27 Rubber	32
4033074070	Drawer unit	544	400	693	693		30



TOOL CABINETS, KNOCK DOWN

- Lockable.
 - Contains 1 or 2 drawers and 1 adjustable shelf.
 - Powder coated.
 - RAL Blue 5010, Grey 7035.

Item No	4010071631	4010071632
Identification	Tool cabinet, knock down 1 door	Tool cabinet, knock down 2 doors
Height mm	900	900
Width mm	500	1000
Depth mm	450	450
Weight kg	16	28

Item No 4010071631



NEW



Item No 4010071632



The 4010071631 together with accessories 4091071637 (tilted top with lid) and 4091071638 (Wheel base).

Item No	Identification	Width mm	Depth mm	Height mm	Weight kg	Capacity in kg per drawer	Total capacity in kg	Wheel diameter x width mm
4033074020	Tool trolley Oak 5+1	1025	600	900	97	40	600	130x40
4033074021	Tool trolley Vinyl 5+1	1025	600	900	97	40	600	130x40
4033074030	Tool trolley Oak 5+5	1025	600	900	121	40	600	130x40
4033074031	Tool trolley Vinyl 5+5	1025	600	900	121	40	600	130x40
4033074040	Attachment kit	925		825	20			

MOBILE FLEX TROLLEY

Mobile storage trolley with perforated tool panels on the sides and 2 shelves. Equipped with four castors, two with brakes. The perforated panels have 9 mm square holes with cc 38 mm for hanging of tool hooks.
- RAL Blue 5005, Grey 7038.

Item No 4033074010
+ 4033074011



Item No 4033074010



Item No 4033074011

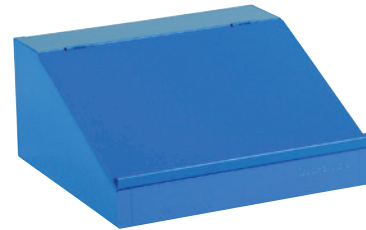

Item No	Width mm	Depth mm	Height back mm	Height front mm	Weight kg	Wheel diameter x width mm
4033074010 + 4033074011	490	445	1310	1175	44	75x20
4033074010	490	445	1080	1080	40	75x20
4033074011	490	445	230	100	4	



WRITING DESK

The writing desk is intended for installation on Item No 4033074010, on the wall or stand-alone. The writing desk has a hinged writing surface equipped with a raised edge and a paper storage unit.

TOOL CABINET

Stable welded tool cabinet in a very robust design.
- Lockable.
- Powder coated.
- Adjustable feet.
- RAL Blue 5005, Grey 7038.

4032074000 INCLUDES:

- Perforated panels in the back, walls and door.
- 2 fixed shelves.
- 1 telescopic shelf with ball bearings.
- 1 telescopic drawer with ball bearings.
- 1 drawer unit with 6 drawers.
- 1 Hanging strip with 7 plastic bins.
- 1 pcs Hook kit with 30 mixed hooks. (Item No 4038074113).

4032074002 INCLUDES:

- 4 fixed shelves.

Item No	Width mm	Depth mm	Height mm	Weight kg
4032074000	1020	540	2000	150
4032074002	1020	540	2000	100

Item No 4032074000



Drawer unit with 6 drawers
Item No 4032074911



Telescopic drawer
Item No 4032074906



Telescopic shelf
Item No 4032074907



Fixed shelf
Item No 4032074908



Tool panels

Item No	Placing
4038074100	Back
4032074909	Door
4032074905	Sides

NEW

Item No 4032074002



MOBILE TOOL CABINET

Equipped with one fixed shelf, writing desk covered in rubber and a pen holder. Supplied with 4 solid rubber wheels with brakes. Both the door and the writing desk can be locked securely with cylinder locks. Powder coated for the best finish and durability.
- RAL Blue 5005, Grey 7038.

Item No 4012071400

Item No	Width mm	Depth mm	Height back mm	Height front mm	Weight kg	Wheel diameter x width mm
4012071400	500	500	1270	1100	29	100x30



TOOL PANELS

The perforated panels have 10 mm square holes with cc 36,5 mm for hanging of tool hooks. Panel 4038074100 and 4038074102 is equipped with integrated hanging attachments.

Panel 4038074105 is intended for wall mounting.

Item No 4038074100

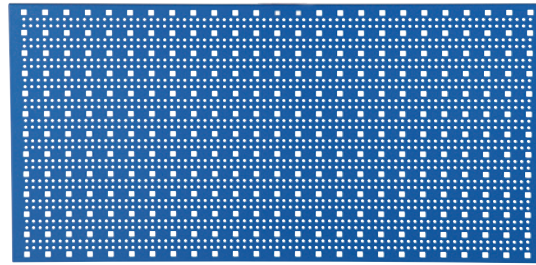

Item No	Width mm	Height mm	Depth mm	Weight kg	RAL color
4038074100	896	480	15	5	Blue 5005
4038074101	896	480	15	5	Grey 7038
4038074102	666	480	15	3	Blue 5005
4038074103	666	480	15	3	Grey 7038
4038074105	1950	900	15	15	Blue 5005
4038074106	1950	900	15	15	Grey 7038
4038082016	750	600	20	3	Grey 7038

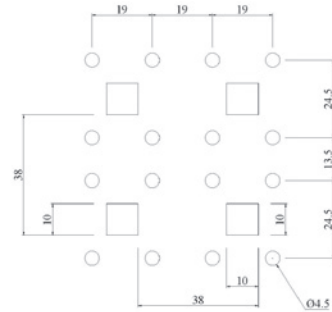

HOOK SETS

Hook set 20 pack

Hanging hook 100 mm, 4 pieces.
Single hook 50 mm, 6 pieces.
Spring clip 12 mm, 3 pieces.
Spring clip 18 mm, 3 pieces.
Double hook 55 x 25 mm, 4 pieces.

Item No 4038074112 (20-pack)

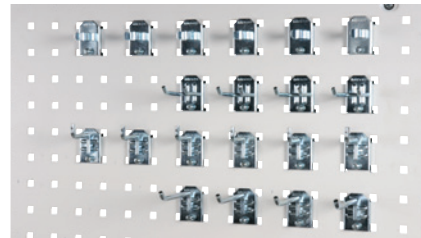

Item No 4038074113 (30-pack)

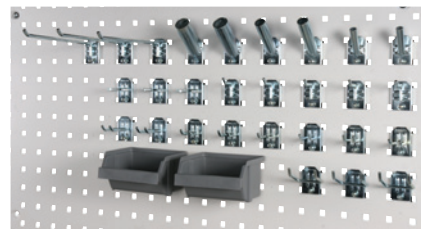

Item No 4038074115 (50-pack)

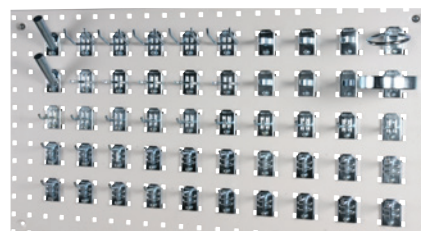

Hook set 30 pack

Hanging hook 38 mm, 5 pieces.
Hanging hook 200 mm, 3 pieces.
Double hook 38x11 mm, 6 pieces.
Double hook 64x11 mm, 2 pieces.
Tool hook 23/44 mm, 3 pieces.
Double angle hook 50 mm, 3 pieces.
Box holder, incl. box, 2 pieces.
Pipe holder 9 mm, 2 pieces.
Pipe holder 16 mm, 2 pieces.
Pipe holder 24 mm, 2 pieces.

Hook set 50 pack

Hanging hook 38 mm, 20 pieces.
Double hook 38x11 mm, 10 pieces.
Tool hook 23/44 mm, 5 pieces.
Double angle hook 50 mm, 5 pieces.
Ring hook 40 mm, 1 piece.
Ring hook 60 mm, 1 piece.
Spring clip 12 mm, 5 pieces.
Pipe holder 16 mm, 2 pieces.
Cup 82 mm, 1 piece.

ASSORTED HOOKS

Item No 4038074140-4038074153

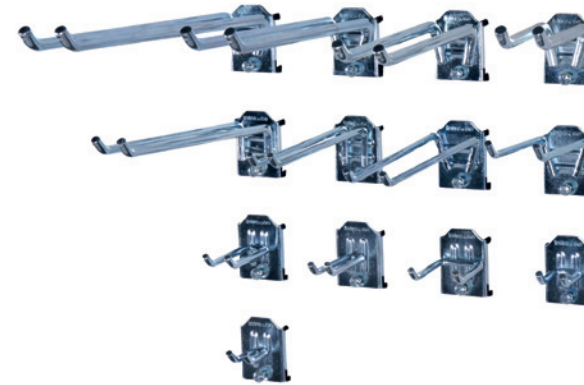

Item No 4038074128-4038074133

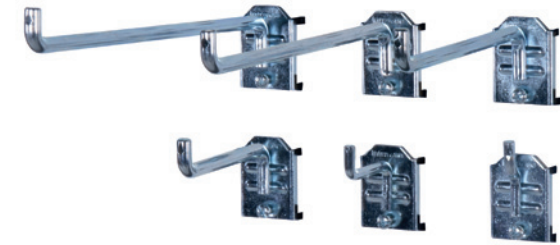

Item No 4038074138-4038074139

Item No 4038074120



Item No 4038074155

Item No 4038074170-4038074173



Item No 4038074135-4038074137

Item No 4038074195



Item No 4038074196



Item No 4038074191



Item No 4038074122-4038074125



Item No 4038074190



Item No 4038074160-4038074163



Item No 4038074216-4038074217



Item No 4038074200-4038074203



Item No 4038074175-4038074176

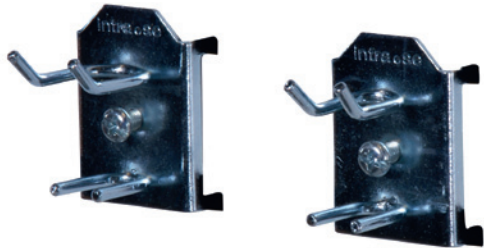

Item No 4038074178



Item No 4038074165



Item No 4038074234



Item No 4038074183-4038074185



Item No 4038074212



Item No 4038074188



Item No 4038074205



Item No 4038074207



Item No 4038074199



Item No 4038074214

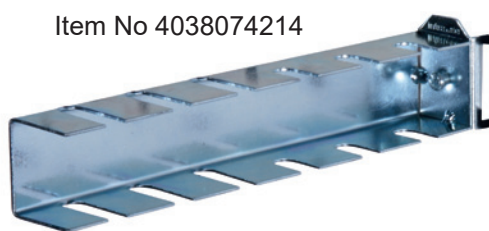

Item No 4038074220

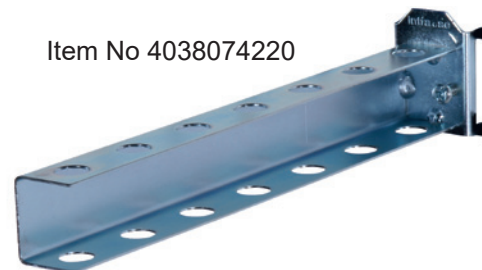

Item No 4038074228



Item No 4038074180-4038074181



Item No 4038074222

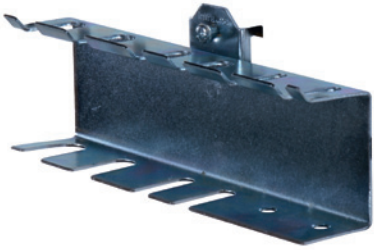

Item No 4038074236

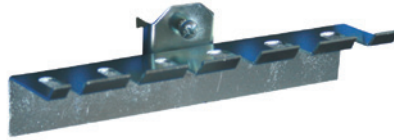

Item No 4038074230



Item No 4038074231



Item No 4038074225



Item No 4038074232



Item No 4038074210



Item No	Identification	Length mm	Width mm	Depth mm	Diameter mm	Height mm	Number per package
4038074120	Base plate	34				40	3
4038074122	Hanging hook	24			5		3
4038074123	Hanging hook	38			5		3
4038074124	Hanging hook	100			6		3
4038074125	Hanging hook	200			6		3
4038074128	Single hook	10			6		3
4038074129	Single hook	50			6		3
4038074130	Single hook	100			8		3
4038074131	Single hook	150			8		3
4038074132	Single hook	200			8		3
4038074133	Single hook	250			8		3
4038074135	Angled single hook	25			5		3
4038074136	Angled single hook	50			5		3
4038074137	Angled single hook	100			5		3
4038074138	Round hook				60		3
4038074139	Round hook				80		3
4038074140	Double hook	38	7		5		3

Item No	Identification	Length mm	Width mm	Depth mm	Diameter mm	Height mm	Number per package
4038074141	Double hook	38	11		5		3
4038074142	Double hook	55	25		5		3
4038074143	Double hook	64	7		5		3
4038074144	Double hook	64	11		5		3
4038074145	Double hook	100	25		5		3
4038074146	Double hook	150	25		5		3
4038074147	Double hook	150	10		5		3
4038074148	Double hook	200	15		6		3
4038074150	Double hook	100	20		8		3
4038074151	Double hook	150	20		8		3
4038074152	Double hook	200	20		8		3
4038074153	Double hook	250	20		8		3
4038074155	Packaging hook	170	29				2
4038074160	Ring hook				40		2
4038074161	Ring hook				60		2
4038074162	Ring hook				80		2
4038074163	Ring hook				110		1
4038074165	Bottle hook				80		1
4038074167	Tool hook		43	20			3
4038074168	Tool hook		65	35			3
4038074170	Angle hook	50	40				3
4038074171	Angle hook	50	60				3
4038074173	Angle hook	70	80				3
4038074175	Swivel joint wrench hook	28	9				3
4038074176	Swivel joint wrench hook	33	17				3
4038074178	Document clip		60				1
4038074180	Rubber clip	25	40				2
4038074181	Rubber clip	50	40				2
4038074183	Spring clip				12		3
4038074184	Spring clip				18		3
4038074185	Spring clip				25		3
4038074188	Spring clip strip,		150				1
4038074190	Box holder, incl. box		100				1
4038074191	Box holder, excl. box		100				1
4038074195	Tray strip, incl 5 trays		555				1
4038074196	Tray strip, excl. trays		555				1
4038074199	Wire basket	385		180		100	1
4038074200	Pipe holder	70			35		2
4038074201	Pipe holder	50			9		2
4038074202	Pipe holder	75			16		2
4038074203	Pipe holder	75			24		2
4038074205	Pipe holder, straight	60			34		2
4038074207	Cup				90	22	1
4038074210	Shelf	350		120			1
4038074212	Hose shelf			160	125		1
4038074214	Hook strip, 6 holes	220					1
4038074216	Hook bobbin	100	80				1
4038074217	Hook bobbin	200	105				1
4038074220	Screwdriver holder, 7 holes	220					1
4038074222	Screwdriver holder	238					1
4038074225	Drill bit holder	240			3 - 14 mm		1
4038074228	Spanner holder, vertical		70			290	1
4038074231	Spanner holder	200					1
4038074232	Box spanner holder	250					1
4038074234	Allen key holder		170	105		40	1
4038074236	Swivel joint wrench holder	170					1

COMPUTER CABINET

A compact and smart computer cabinet for mounting on wall or table top. Equipped with a lockable door on the side and a pull-out drawer for keyboard and mouse. Self ventilated with punched holes on the side. Delivered in a flatpack for the best transport economy. Suitable for screens up to 24 inches. Color grey, RAL 7035.

Item No 4031071156



Item No	4031071156
Height mm	595
Depth mm	450
Width mm	640
Weight kg	16
Window size mm	550x360
Max screen width (inne width) mm	610

COMPUTER CABINET

Computer cabinet with self-ventilation. Supplied unassembled in order to ensure the best transport possible from an economic and environmental perspective. The cabinet protects against dust and dirt. It provides good protection against unauthorised users and mechanical damage. Powder coated for the best finish and durability. Suitable for screens up to 21 inches. - RAL Blue 5010, Grey 7035.

Item No 4031071150



Item No	4031071150
Height mm	1730
Depth mm	545
Width mm	645
Weight kg	50
Window size mm	460x440
Max screen width (inne width) mm	630



COMPUTER CABINET

A compact and well thought out computer cabinets for flat screen. Extra reinforced folding shelf for keyboard and mouse. Secure locking of doors and hatches with code locks. Supplied unassembled for the best transport economy. Suitable for screens up to 23 inches.

Item No 4031071152

Item No 4031071154



Item No	4031071152	4031071154
Height mm	1730	1730
Depth mm	280	280
Width mm	640	640
Weight kg	31	31
Window size mm	460x405	460x405
Max screen width (inner width) mm	630	630
RAL Color	Blue 5010 / Grey 7035	Grey 7035

COMPUTER CABINET

Computer cabinet for flat screens. It takes up little space as its depth is only 300 mm. The computer is placed crosswise through the hatch on the short end. There is a service hatch on the side. The cabinet is equipped with a keyboard shelf and a terminal window for screens. All doors are equipped with locks. The keyboard shelf has a telescopic mouse board. The bottom cabinet contains one fixed shelf. Powder coated for the best finish and durability.

Item No 4031074080

It is recommended to attach / anchor the computer cabinet to the wall. Suitable for screens up to 21 inches. - RAL Blue 5005, Grey 7038.

Item No	4031074080
Height mm	1630
Depth mm	325
Width mm	650
Weight kg	40
Window size mm	450x380
Max screen width (inne width) mm	640





SHELVING UNITS – T17A

Strong galvanised shelving unit for the warehouse, workshop, archive, office, food industry, shop, etc.

Strong shelving units with MDF shelves. Easily assembled without any screws. Suitable for all purposes in offices, workshops, shops or elsewhere. Supplied complete with 5 shelves!

Item No	4210072175
Identification	T17
Width mm	900
Depth mm	400
Height mm	1800
Capacity kg	175

Item No 4210072175



RACKS AND STORAGE

UNIVERSAL SHELF/ TYRE SHELF

Very stable construction with heavy duty beams that have dual attachment points on each side. Item no 4050072184 and 4050072182 are steelplates for the shelves delivered in 4-pack.
- RAL Uprights 7016, Beams 7042, Shelves 7042.

Item No	4050072183	4050072181	4050072184	4050072182
Height mm	2400	2400	-	-
Depth mm	450	450	450	450
Width mm	1200	1400	1200	1400
free distance between poles mm	1120	1320	-	-
Max load kg	300 per shelf	300 per shelf	-	-



Item No 4050072183



UNIVERSAL SHELVES / SHELVING SYSTEMS

Easily installed shelving units intended for large volume goods.
 Easy and flexible to extend where required.
 The units must be bolted to the floor.
 Safety pins for locking beams to uprights.
 Spacers must be used in the rear in the event of rear mounting.
 The spacer for the universal shelves must be 200 mm (Item No 4050072082).
 The spacer for the tyre shelves must be 300 mm (Item No 4050072084).
 Recommendation: 3 spacers per upright.
 Bolts and nuts are not included with the spacers!
 - RAL Uprights 7016, Beams 7042



19 mm chipboard!



BEAMS

Item No	4050072050	4050072051	4050072052
Identification	Beam	Beam	Beam
Length mm	1500	2000	2700
Max load kg	580 per pair	400 per pair	220 per pair

UPRIGHTS

Item No	4050072056	4050072058	4050072060	4050072062	4050072064	4050072066
Identification	Uprights 2000x450 mm (HxD)	Uprights 2500x450 mm (HxD)	Uprights 3000x450 mm (HxD)	Uprights 2000x600 mm (HxD)	Uprights 2500x600 mm (HxD)	Uprights 3000x600 mm (HxD)

CHIPBOARDS

Item No	4050072068	4050072070	4050072071	4050072072	4050072074	4050072076
Identification	Chipboard	Chipboard	Chipboard	Chipboard	Chipboard	Chipboard
Length x Width mm	1485x398	1985x398	2685x398	1485x550	1985x550	2685x550

SAFETY PIN



SPACER



SPACER

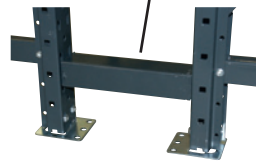

Bolts and nuts are not included with the spacers!

ACCESSORIES

Item No	4050072080	4050072082	4050072084
Identification	Safety pin	Spacer 200 mm	Spacer 300 mm
Quantity per package	2	1	1

TYRE SHELF

The same design as the Universal shelf but without chipboards. The uprights for the tyre shelves must be 450 mm deep – adapted to the dimensions of the tyres.

Example

FIGURE 1 = 3 uprights (Item No 4050072058) + 12 beams (Item No 4050072051) = Capacity 60 tyres.



HYLLO - STORAGE SYSTEM

HYLLO storage system is a complete system for your work-place. You customize it according to your needs and products when you can expand it without boundaries from a basic section. With its robust construction, HYLLO can handle high loads and is well suited for everything from store to industrial environment. The shelves are mounted very easily and all accessories are of the same flexible mounting structure so you can get your HYLLO system exactly as you wish. Loading capacity 250kg per shelf or 1500kg per section.

The HYLLO accessories are tailored to market requirements and allow you to customize your system. With tool panels, drawers, shelves with collection and much more, HYLLO offers you everything you may need in storage. RAL Grey 7038 / Blue 5005.

Item No 4034076001 Item No 4034076007



Item No	4034076001	4034076002	4034076003	4034076004	4034076005	4034076006	4034076007	4034076008
Identification	Kit 1 Shelves Base	Kit 2 Shelves Extension	Kit 3 Shelves Base	Kit 4 Shelves Extension	Kit 5 Tilted Shelves Base	Kit 6 Tilted Shelves Extension	Kit 7 Tilted Shelves Base	Kit 8 Tilted Shelves Extension
No of gables	2	1	2	1	2	1	2	1
Width mm	1000	1000	500	500	1000	1000	500	500
Height mm	2000	2000	2000	2000	2000	2000	2000	2000
Depth mm	500	500	500	500	500	500	500	500

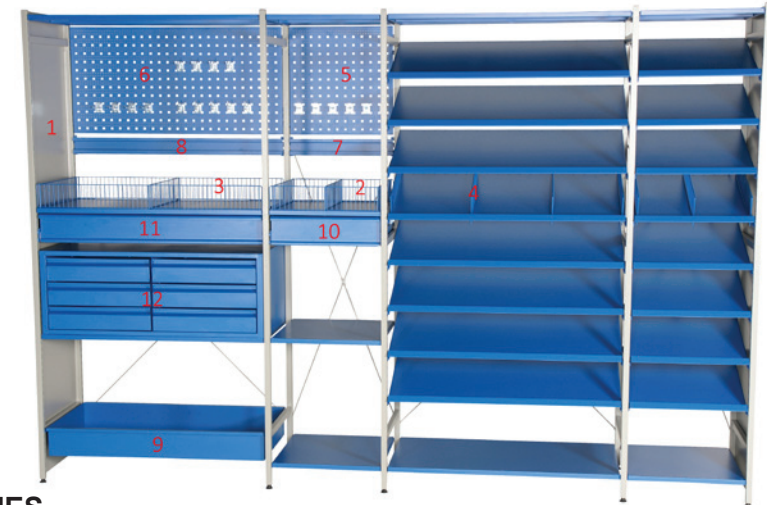

ACCESSORIES

Item No	4034076509	4034076510	4034076511	4034076512	4034076513	4034076514	4034076516
Identification	No: 1 Gable Covers	No: 2 Dividers front and back	No: 3 Dividers front and back	No: 4 Dividers middle	No: 5 Tool panel 500mm	No: 6 Tool panel 1000mm	No: 7 Combo rail 500mm
Includes no	2	2	2	5	1	1	1
Width mm	500	500	1000	500	500	1000	500
Height mm	2000	150	150	150	500	500	100

Item No	4034076517	4034076519	4034076521	4034076522	4034076523	4034076526	4034076527
Identification	No: 8 Combo rail 1000mm	No: 9 Chemical shelf	No: 10 Single drawer 500mm	No: 11 Single drawer 1000mm	No: 12 6 Drawer unit	Cable drum holder 500mm	Cable drum holder 1000mm
Includes no	1	1	1	1	1	1	1
Width mm	1000	1000	500	1000	1000	500	1000
Height mm	100	130	140	140	360	35	35

STEP STOOL, 1 STEP PLASTIC

Step stool with one step manufactured entirely of plastic. Three wheels for easy moving of the step stool; locked automatically once you step on the stool. Maximum load of up to 150 kg. Suitable for shops, warehouses and offices etc.



Item No	4111034100	4111034101	4111034102	4111034103
Colour RAL	Grey 7035	Black 9005	Blue 5005	Red 3020
Ø mm Top	300	300	300	300
Ø mm Bottom	390	390	390	390
Maximum load Kg	150	150	150	150
Weight kg	1,6	1,6	1,6	1,6
Height mm	300	300	300	300

Item No 4111034103



STEP STOOL, 2 STEP PLASTIC

Step stool with two step manufactured entirely of plastic. Three wheels for easy moving of the step stool; locked automatically once you step on the stool. Maximum load of up to 150 kg. Suitable for shops, warehouses and offices etc.

Item No	4111034200	4111034201	4111034202	4111034203
Colour RAL	Grey 7035	Black 9005	Blue 5005	Red 3020
Ø mm Top	283	283	283	283
Ø mm Bottom	433	433	433	433
Maximum load Kg	150	150	150	150
Weight kg	2,1	2,1	2,1	2,1
Height mm	410	410	410	410

Item No 4111034202



STEP STOOL, 2 STEP METAL

Step stool of painted sheet metal with spring-loaded wheels. The stool is stable and secure and you can move it easily by pushing it slightly with your foot. When pressure is applied to the stool, the spring-loaded wheels are pressed in and the stool remains steady. The steps are covered in ribbed rubber in order to minimise the risk of slipping. Suitable for shops, warehouses and offices etc.

Item No	4072034300	4072034301	4072034302	4072034303
Colour RAL	Grey 7035	Black 9005	Blue 5005	Red 3020
Ø mm Top	289	289	289	289
Ø mm Bottom	433	433	433	433
Maximum load Kg	150	150	150	150
Weight kg	5	5	5	5
Height mm	410	410	410	410

Item No 4072034301



STORAGE CABINET ECONOMY

For office, archive and warehouse. Stable unassembled steel cupboard. Due to its clever design, it is easily assembled without any screws and tools.

- Espagnolette lock with three locking points.
- Supplied with 4 shelves!
- Loading capacity of 50 kg evenly distributed per shelf.
- Powder coated in blue with grey base or full grey.
- In order to attach the panels, holes must be drilled in the desired places and the panels must be screwed tight.

Item No	4010571601	4010571603	4010571611
Identification	Economy-Blue / Grey	Economy-Grey	Extra shelf Grey
Height mm	1800	1800	20
Width mm	900	900	895
Depth mm	400	400	364
Weight kg	41,5	41,5	1,85
Color RAL	Blue 5010 / Grey 7035	Grey 7035	Grey 7035

Item No 4010571601



STORAGE CABINETS

For office, archive and warehouse. Stable unassembled steel cupboard. Due to its clever design, it is easily assembled without any screws and tools.

- Espagnolette lock with three locking points.
- Supplied with 2 shelves.
- Prepared for wall mounting. Screws and plugs are included.
- Loading capacity of 70 kg evenly distributed per shelf. (New HD shelves now available for capacity up to 100kg)
- Powder coated.



Item No 4010071225



Item No 4010071015

Item No	4010071015	4010071025	4010071215	4010071225
Identification	SWED 100 Blue	SWED 100 Grey	SWED 90 Blue	SWED 90 Grey
Height mm	1000	1000	900	900
Width mm	1000	1000	800	800
Depth mm	500	500	400	400
Weight kg	46	46	28	28
Color RAL	Blue 5010	Grey 7035	Blue 5010	Grey 7035



STORAGE CABINETS

For office, archive and warehouse. Stable unassembled steel cupboard. Due to its clever design, it is easily assembled without any screws and tools.

- Espagnolette lock with three locking points.
- Supplied with 4 shelves!
- Loading capacity of 70 kg evenly distributed per shelf.
- (New HD shelves now available for capacity up to 100kg)
- Powder coated.
- In order to attach the panels, holes must be drilled in the desired places and the panels must be screwed tight.

Item No 4091071012 + 4038074102



Accessories for cabinets

Item No	4091071212	4091071012	4038074100	4038074102	4010071213	4010071223	4010071013	4010071023
Identification	Telescopic drawer	Telescopic drawer	Panel	Panel	Heavy Duty shelf	Heavy Duty shelf	Heavy Duty shelf	Heavy Duty shelf
Height mm	70	80	480	480	20	20	20	20
Width mm	640	840	896	666	795	795	995	995
Depth mm	330	420	18	18	355	355	460	460
Color RAL	Blue 5010	Blue 5010	Blue 5005	Blue 5005	Blue 5010	Grey 7035	Blue 5010	Grey 7035

Item No 4010071010



Item No 4010071220

Item No	4010071210	4010071211	4010071220	4010071221	4010071010	4010071011	4010071020	4010071021
Identification	Swed-180 Blue	Extra shelf Blue	Swed-180 Grey	Extra shelf Grey	Swed-3 Blue	Extra shelf Blue	Swed-3 Grey	Extra shelf Grey
Height mm	1800	20	1800	20	2000	20	2000	20
Width mm	800	795	800	795	1000	995	1000	995
Depth mm	400	355	400	355	500	460	500	460
Weight kg	46	0,5	46	0,5	64	1	64	1
Color RAL	Blue 5010	Blue 5010	Grey 7035	Grey 7035	Blue 5010	Blue 5010	Grey 7035	Grey 7035

DRAWER UNITS FOR STORAGE CABINETS

Drawer units for SWED-cabinets. 6 drawers is suitable for SWED 3 cabinets. 3 drawers is suitable for SWED 180.

Item No	4091071014	4091071024	4091071214	4091071224
Identification	6 Drawers Blue	6 Drawers Grey	3 Drawers Blue	3 Drawers Grey
Height mm	414	414	414	414
Width mm	922	922	722	722
Depth mm	446	446	346	346
Weight kg	30	30	16,5	16,5
Color RAL	Blue 5010	Grey 7035	Blue 5010	Grey 7035

Item No 4091071024



Item No 4091071214



NEW

FOLDABLE STORAGE CABINET

Our revolutionary folding cabinet for office, archive, warehouse, etc. Saving shipping costs and the environment, due to its flat design, it takes considerably less space during storage and transportation than a welded cabinet. No assembly required as it easily folds out and fixes in less than 1 minute. It is also easy to fold the cabinet if used for seasonal sales or storage. This is simply the smartest solution for storage for you and the environment! Including 3 fixed shelves. Extra shelves not possible. RAL Grey 7035 / Blue 5010.

Item No	4010571652	4010571654
Identification	SWED Easy Blue	SWED Easy Grey
Height mm	1800	1800
Width mm	900	900
Depth mm	400	400
Depth folded mm	100	100
Capacity per shelf kg	50	50
Weight kg	45	45



QR-code
Link to
instruction
video



Item No 4010571654



CHEMICAL CABINET

Cabinet for chemical storage with ventilation in the doors. The cabinet is equipped with four adjustable tight welded shelves, designed as a collecting tray with 12 liter capacity.

- Espagnolette lock with three locking points.
- Supplied with 4 shelves. 12 liter capacity each.
- Loading capacity of 75 kg evenly distributed per shelf.
- Powder coated.
- RAL Grey 7035.

Item No	4010071520	4010071521
Identification	Chemical	Extra shelf
Capacity per shelf kg	75	75
Height mm	1950	50
Depth mm	420	370
Width mm	920	912
Weight kg	57	2,36



Item No 4010071520



KEY BOXES

Smart stable key boxes for secure key storage. Supplied complete with key tags. The boxes are equipped with cylinder locks, including 2 keys.

- Powder coated.
- RAL Grey 7035.

Item No 4021071132



Item No 4021071140



Item No	4021071132	4021071130	4021071140	4021071134
Height mm	400	400	650	650
Depth mm	70	70	70	140
Width mm	350	350	350	390
Weight kg	2,8	3	4,7	9
Number of keys	30	60	100	200

Item No 4015071110



Item No 4015071120



SMALL STORAGE LOCKERS

Unassembled small storage lockers for storing personal belongings in workplaces, schools, hospitals, sports centres, shops, offices, etc. Supplied unassembled in flat-pack to ensure the best and cheapest transport.

Due to its very smart design, the lockers are assembled quick and easy without any tools and screws. The locker modules are provided with holes so that they can be assembled together in accordance with your own desires and, alternatively, for wall mounting. The lockers have recessed, hidden hinges and cylinder locks for secure storage.

- Powder coated.
- RAL Grey 7035.

Item No	4015071110	4015071120
Height mm	275	455
Width mm	275	275
Depth mm	355	355
Weight kg	5	7



STORAGE LOCKERS

Due to their smart design, they are easily assembled without any screws and tools.
Sloping roof for simple cleaning.

- Cylinder locks.
- Powder coated doors in RAL color blue 5010 or red 3020.
- Base in RAL Color grey 7035.



Accessories: Base kit,
Item No 4091071390
Base height: 100 mm



Accessories: Bench,
Item No 4091071395
Bench height: 260 mm

Item No 4011071353



Item No 4011071340



LOCKERS

Due to its smart design, it is easily assembled without any screws and tools. Sloping roof for simple cleaning.
Well ventilated with a double ventilation grill.

- Cylinder locks.
- Powder coated doors in RAL color blue 5010 or red 3020.
- Base in RAL Color grey 7035.



Accessories: Base kit,
Item No 4091071390
Base height: 100 mm



Accessories: Bench,
Item No 4091071395
Bench height: 260 mm



Item No 4011071334



Item No 4011071332



Item No	4011071340	4011071350	4011071342	4011071352
Identification	Blue/Grey	Blue/Grey	Red/Grey	Red/Grey
Number of doors	4	5	4	5
Height front edge mm	1830	1830	1830	1830
Height back edge mm	1920	1920	1920	1920
Width mm	350	350	350	350
Depth mm	550	550	550	550
Weight kg	29	31	29	31

Item No	4011071341	4011071351	4011071343	4011071353
Identification	Blue/Grey	Blue/Grey	Red/Grey	Red/Grey
Number of doors	8	10	8	10
Height front edge mm	1830	1830	1830	1830
Height back edge mm	1920	1920	1920	1920
Width mm	700	700	700	700
Depth mm	550	550	550	550
Weight kg	55	70	55	70

Item No	4011071330	4011071332	4011071334	4011071336
Identification	Blue/Grey	Blue/Grey	Red/Grey	Red/Grey
Number of doors	2	4	2	4
Height front edge mm	1830	1830	1830	1830
Height back edge mm	1920	1920	1920	1920
Width mm	350	700	350	700
Depth mm	550	550	550	550
Weight kg	25	45	25	45



Accessories: Latch for padlocks
Item No 4090071394



Accessories: Latch for padlocks
Item No 4090071394

LOCKERS

Due to their clever design, they are easily assembled without any screws and tools. Sloping roof for simple cleaning. Well ventilated with a double ventilation grill.

- Cylinder locks.
- Powder coated doors in RAL color blue 5010 or red 3020.
- Base in RAL Color grey 7035.

Item No 4011071310



Item No 4011071321



Accessories: Base kit,
Item No 4091071390
Base height: 100 mm



Accessories: Bench,
Item No 4091071395
Bench height: 260 mm



Accessories: Latch for padlocks
Item No 4090071394

Item No	4011071310	4011071320	4011071311	4011071321
Identification	SWED-1 Blue/Grey	SWED-2 Blue/Grey	SWED-1 Red/Grey	SWED-2 Red/Grey
Number of doors	1	2	1	2
Height front edge mm	1830	1830	1830	1830
Height back edge mm	1920	1920	1920	1920
Width mm	350	700	350	700
Depth mm	550	550	550	550
Weight kg	25	45	25	45

Z - LOCKERS

Due to its clever design, it is easily assembled without any screws and tools. Sloping roof for simple cleaning. Well ventilated with a double ventilation grill.

- Cylinder locks.
- Powder coated doors in RAL color blue 5010 or red 3020.
- Base in RAL Color grey 7035.

Item No 4011071364



Accessories: Base kit,
Item No 4091071390
Base height: 100 mm

Item No 4011071362



Accessories: Bench,
Item No 4091071396
Bench height: 260 mm

Item No	4011071360	4011071362	4011071364	4011071366
Identification	Blue/Grey	Blue/Grey	Red/Grey	Red/Grey
Number of doors	2	4	2	4
Height front edge mm	1830	1830	1830	1830
Height back edge mm	1920	1920	1920	1920
Width mm	400	800	400	800
Depth mm	550	550	550	550
Weight kg	25	45	25	45



RuXXac HAND TRUCK

- The best quality on the market!
- When folded, extremely space saving.
- New rolling function when folded.
- Patented folding technology - Ready to use in seconds.
- Comfortable steering due to synthetic handle.
- Unique load-securing system fixes load perfectly on the cart.
- Load capacity up to 250 kg.
- Solid rubber tires.



Item No 1910057420

Item No 1910057430

Rolling function when folded

Item No 1910057410



Item No 1910057440

Item No 1910057450

Item No 1910057460



TRANSPORT AND LIFTING



Item No	1910057410	1910057420	1910057430	1910057440	1910057450	1910057460
Identification	Business	Business XL	Exclusive	Parcel Cart	Cross	Jumbo
Loading capacity Kg	125	125	125	125	100	250
Height open mm	1030	1130	1130	1100	1120	1250
Height folded mm	685	730	730	1100	74	84
Width mm	490	490	490	490	615	655
Thickness folded mm	55	55	55	110	120	120
Platform mm	490x250	490x410	490x410	490x410	495x420	570x345
Weight kg	5,4	6,1	5,9	6	6,3	11,4
Wheel Ø mm	Solid rubber 180 mm Ø	Solid rubber 180 mm Ø	Solid rubber 180 mm Ø	Solid rubber 185 mm Ø	Extra wide 180 mm Ø	Solid Rubber 215 mm Ø
Frame material	Aluminum	Aluminum	Stainless steel	Aluminum	Aluminum	Aluminum

FOLDABLE HAND TRUCK

A light and flexible sack trolley in aluminum that folds easily after use for transport or storage. With its strong construction, it is a perfect aid when moving heavy loads. The obvious choice for you who need to move heavy goods in a fast and smooth way.

Item No	1910057380	1910057385
Identification	H-003B-1	H-003LN
Loading capacity Kg	100	200
Height open mm	1080	1285
Height folded mm	835	1052
Width mm	490	635
Thickness folded mm	70	124
Platform mm	350x480	390x610
Weight kg	5	11
Wheel Ø mm	Solid rubber 170 mm Ø	Solid rubber 200 mm Ø
Frame material	Aluminum	Aluminum

Item 1910057380

NEW

Item 1910057385



HAND TRUCK WITH LADDER

Practical, stable hand truck combined with ladder! Perfect tool for the craftsman.

Item No	1910039101
Opening size LxWxD mm	880x500x410
Folded size LxWxD mm	1054x500x80
Material:	Steel tube, Stair:PP + Fiber
Net weight kg	8.5
Load capacity kg	135
Wheels mm	150x40 Rubber



Item No 1910039101

COMBI HAND TRUCK IN ALUMINUM

3-position trolley with extra long loadplate if necessary. Easy to change position.

Item No	1910057391
Identification	A107
Loading nose plate mm:	700x200
Width of wheels mm:	470
Wheel type	Filled
Width mm	527
Height mm	1303
Weight kg	16
Capacity 2 wheels kg	250
Capacity 4 wheels kg	350



Art nr 1910057391

ALUMINUM HAND TRUCK

Aluminum hand truck with folding platform and sliding rails for smooth handling even in stairs. A powerful yet lightweight and stylish cart and hand truck. Foam-filled large tires make sure you do not need to worry about flat tires! The best option for you who place high demands on your equipment!

Item No	1910057392
Identification	HS-1
Loading plate mm	540x300x38
Width of wheels mm	500
Width of handle mm	295
Wheel diameter mm	240
Height mm	1265
Weight kg	12
Capacity kg	250

Art nr 1910057392

Slide rails for easy sliding down in stairs.



ALUMINUM HAND TRUCK

Aluminum hand truck with folding platform and sliding rails for smooth handling even in stairs. It is strong and smooth for loading up to 180 kg. The large foam-filled wheels allow you to use the trolley daily without risk of puncture. Simply a perfect cart to handle everyday work and transports.

Item No	1910057395
Identification	HT 1878
Loading plate mm	290x300
Width of wheels mm	500
Width of handle mm	490
Wheel diameter mm	260
Height mm	1310
Weight kg	12
Capacity kg	180

Art nr 1910057395

Slide rails for easy sliding down in stairs.

Filled tiers.



ALUMINUM HAND TRUCK, TOP QUALITY!

A106s strength has made it the most affordable AL trolley for moving the industry. It is the best use for all areas with cargo handling. It is equipped with a folding loading plate, filled tiers, handle with protection for the hands, slide rails for stair climbing, strengthened holders for handles.

Item No	1910057390
Identification	A106
Loading plate mm	270x370
Width of wheels mm	470
Width of handle mm	840
Wheel diameter mm	260
Height mm	1310
Weight kg	12
Capacity kg	250

Art nr 1910057390

Slide rails for easy sliding down in stairs.

Filled tiers.



STANDARD TRUCK

Strong and robust standard truck.
Wheel type: Solid PU foam, flat free.



Item No 1910057130

MAGAZINE TRUCK

Strong and robust magazine truck.
Wheel type: Solid PU foam, flat free.



Item No 1910057005

DISTRIBUTION TRUCK

Strong and robust distribution truck.
Collapsible which makes it flexible and easy to transport. Side protection gives the load stability.
Wheel type: Solid PU foam, flat free.



Item No 1910057115

STEP TRUCK

Strong and robust step truck with a Toe plate.



Item No 1910057006

STEP TRUCK

Strong and robust step truck with a Toe plate and a loading platform.



Item No 1910057140

DRUM TRUCK

Strong and robust drum truck. Supplied with a strap for safe drum handling.



Item No 1915057110

Item No	1910057130	1910057005	1910057115	1910057020
Identification	SST	LSP20	DT	HT 1826
Loading capacity Kg	250	350	150	250
Height mm	1150	1200	1060	1110
Width mm	470	460	710	550
Wheel diameter mm	260	260	260	260
Wheel type	Filled	Filled	Filled	Filled
Load plate mm	420x350	330x250	470x320	515x335
Toe plate mm	450x70	-	-	410x170
Weight kg	18	16	16	18

Item No	1910057006	1910057140	1915057110	1910057100
Identification	SSPN35	TRK 200	BTS	WT
Loading capacity Kg	200	200	250	200
Height mm	1300	1250	1350	1665
Width mm	460	550	700	610
Wheel diameter mm	160	150	400	300
Wheel type	Solid rubber	Solid rubber	Pneumatic	Filled
Load plate mm	300x250	500x350	-	-
Weight kg	22	21	20	20

SACK TRUCK

Strong hand truck with 250 kg capacity. Robust in its construction with safety wheel guards, large fixed toe plate, an extra large foldable load plate and large puncture-free PU filled tires. The markets strongest and best alternative to a fantastic price due to our large production volume!



Item No 1910057020

TYRE TRUCK

Flexible and easy-to-handle tyre truck for safe tyre transport. High handles for simple and ergonomic use of the truck in a transport mode.
Wheel type: Solid PU foam, flat free.



Item No 1910057100

ERGONOMIC SHOP AND STORAGE TROLLEY

Smart and flexible shelf trolley in galvanized steel where the height changes depending on the weight of the load. This provides a more ergonomic working height to save back and shoulders.

Item No	1920057256
Length mm	963
Height mm	1445
Width mm	534
Capacity top kg	90
Capacity bottom kg	255
Capacity total max kg	255
Wheel diameter mm	125
Weight kg	25



Item No 1920057256



NEW



SHOP AND STORAGE TROLLEY

Stackable shop and storage trolley. A stable and flexible trolley with two shelves which can cope with a load of up to 300 kg. The surface is galvanised and the handle is covered in plastic for more comfortable use. 4 rubber-covered 125 mm castors with ball bearings for silent and easy handling.

Item No	1920057250
Length mm	1030
Height mm	1020
Width mm	530
Capacity kg	300
Wheel diameter mm	125
Weight kg	22



Item No 1920057250

PLATFORM TROLLEY

Platform trolley with two shelves. Solid steel frame and 10 mm-thick glued laminate board. Capacity of 150 kg evenly distributed per trolley. Supplied unassembled, incl. four rubber-covered castors, two with brakes.

FlatPack

Item No 1920057200



Item No 1920057210



Item No 1920057220



Item No 1920057230



Item No 1920057240



Item No.	1920057200	1920057210	1920057220	1920057230	1920057240
Capacity kg bottom shelf	75	75	75	75	75
Capacity kg top shelf	75	75	75	75	75
Carrying surface per shelf mm	425x765	425x765	425x765	510x710	510x710
Total length mm	830	830	830	766	766
Total width mm	465	465	465	580	580
Total height mm	985	985	985	945	945
Height between shelves mm	515	515	515	355	355
Wheel Ø mm	125	125	125	125	125
Weight kg	14	14	14	18	18

PV330 FOLDABLE SERVICE CART

Smart and flexible platform trolley. Folds easily when you are not using it or when transporting it or to save space. Perfect for builders, narrow warehouses and stores.

Item No 1925057026

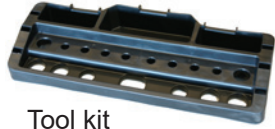

Tool kit



Item No 1925057025



Item No.	1925057025
Total Capacity kg	75
Capacity kg per shelf	25
Carrying surface per shelf mm	590x370
Total length unfolded/folded mm	660/200
Total width unfolded/folded mm	430/430
Total height unfolded/folded mm	860/1070
Height between shelves mm	310
Height of the shelf rail mm	25
Wheel Ø mm	75
Weight kg	7

HEAVY DUTY TROLLEY

Strong trolleys of the absolutely highest quality. Well adapted for heavy and frequent handling of goods in the industry, warehouses, shops, etc. Flexible, you can select your design in accordance with your own needs. Supplied with four 200 mm solid rubber wheel, two with brakes.

Basic design



Short side end piece

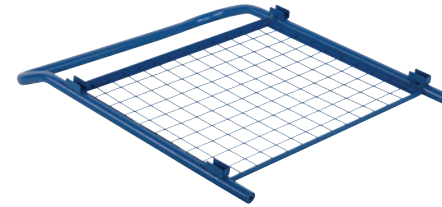

Long side end piece

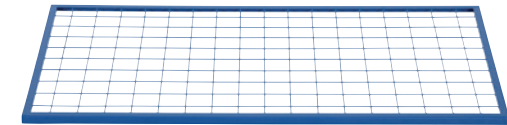

PALLET TROLLEY

Pallet trolley in a robust steel construction with a total capacity of 800kg for easy and smooth transport of EUR pallets in warehouse and industry. Equipped with two fixed wheels and two swivel for smooth movement. Perfect as a mobile workspace with the accessory 1920057372 with which you can adjust the height.

Pallet not included



Item No 1920057370
+ 1920057372

NEW

Item No	Length mm	Width mm	Hight max mm	Hight min mm	Wheels mm	Capacity kg
1920057370	1232	832	325	325	200x45 Rubber	800
1920057372	1232	832	642	468	-	800

Item No 1920057370



Item No 1920057372

Item No	1920057310	1920057320	1920057330	1920057340
Capacity kg	800	800	800	800
Height without end pieces mm	285	285	285	285
Total height, incl. short side end piece	1050	1050	1050	1050
Total width, incl. short side end piece mm	890x520	1040x610	1040x710	1240x810
Load plate mm	835x455	985x555	985x655	1185x755
Wheel diameter mm	200x50 Solid rubber	200x50 Solid rubber	200x50 Solid rubber	200x50 Solid rubber
Weight without end pieces kg	15	20	25	35

ACCESSORIES SHORT SIDE END PIECE

Item No	1920057312	1920057322	1920057332	1920057342
Suitable for	1920057310	1920057320	1920057330	1920057340

ACCESSORIES LONG SIDE END PIECE

Item No	1920057314	1920057324	1920057344
Suitable for	1920057310	1920057320 / 1920057330	1920057340

HEAVY DUTY TROLLEY

Large and sturdy shelf trolleys with two shelves. Adapted for heavy work in all environments. The 200 mm large wheels make the trolleys easy accessible even on uneven ground and takes with ease over thresholds and other obstacles that may exist in a workplace. The bright material on the shelves give a fresh look and a clearer overview of the goods placed on them.



Item No 1920057355

Item No	1920057350	1920057355
Capacity kg	500	500
Total length mm	1150	1350
Total height mm	875	875
Total width mm	700	800
Load plate mm	1000x700	1200x800
Wheel diameter mm	200	200

CLAX, THE CLEVER FOLDING CART

For materials handling in stores, service and office areas. Indispensable for a mechanic or salesman. Handy for the supermarket shopping.

Clax, the clever folding trolley:

- Can be collapsed quickly and easily at the push of a button.
- Has many useful features such as block brake, holding device for boxes, upward folding load platform and removable wheels for space-saving storage.
- Has two large load platforms for folding plastic boxes or beverage containers.
- Comes complete with one Folding Box, Size: 500x340Wx260mm deep inside (46-liters)

Item No	1925056100
Identification	CLAX
Upper tray capacity kg:	20
Lower tray capacity kg:	40
Total capacity kg:	60
Size assembled mm:	890x550x1030
Size folded mm:	670x470x110
Unit weight kg:	7,3

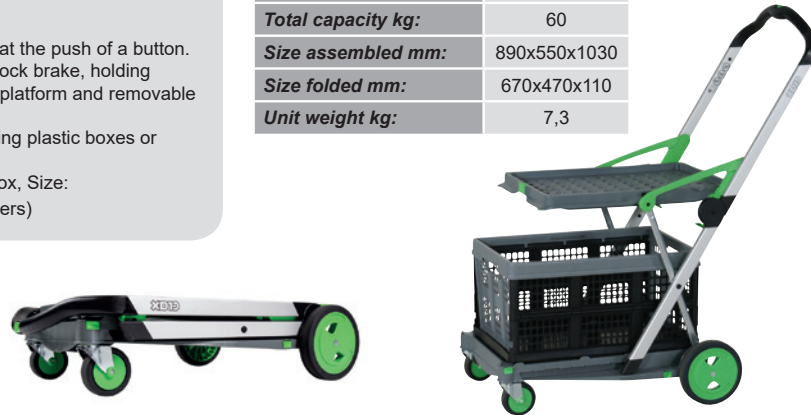

Item No 1925056100

POST TROLLEY

Classic electro zink plated Post trolley that is very popular for shops, schools, offices and lighter warehouses. Especially popular with shops because it is smooth in the small spaces, the baskets hold a lot and keep the goods in place. Equipped with 4 wheels och 2 of them are equipped with a brake that is very practical when loading and unloading. Handle in plastic.

Item No	1920057252
Length mm	715
Height mm	965
Width mm	415
Capacity kg	100
Wheel diameter mm	125
Weight kg	12



Item No 1920057252

STAINLESS PLATFORM TROLLEYS

Smooth platform trolleys in stainless steel that are easy to keep clean. The trolleys are perfect for smooth transportation, storage and food handling in large kitchens, dining rooms and other environments with high standards of hygiene and cleanliness. The platform trolleys are equipped with two to five shelves to suit your needs. The shelf has a rubber mat on the underside to make the trolley as quiet and work environmentally friendly as possible! The four easy-rolled castors are fitted with anti-collision protection to protect the carriage and load against unnecessary shocks. Two of the castors are fitted with a brake, which makes it very easy to lock the trolley in place for example loading and unloading. Simply the best option. Stainless quality: 304



Item No 1920057812

Item No 1920057813

Item No 1920057814

Item No 1920057815

Item No	1920057812	1920057813	1920057814	1920057815
Capacity Kg	50 per shelf	50 per shelf	50 per shelf	50 per shelf
Height between shelves mm	565	310	310	310
Total height mm	950	950	1250	1550
Width mm	525	525	525	525
Length mm	845	845	845	845
Weight kg	14	15	17	19

PALLET CAGE / PACKAGE CAGES

Strong and robust pallet cages. Easily and simply assembled without any tools.

You can save storage space by stacking the cages on top of each other.

Item No 2340059214



Item No	2340059210	2340059212	2340059214	2340059216
Capacity Kg:	500 per cage	500 per cage	500 per cage	500 per cage
External dimensions mm LxWxH	1200*800*800	1200*800*1000	1200*800*1200	1200*800*1600
Weight kg	25	30	35	40

CRATE / TRAY / CARTON TROLLEYS

Robust trolleys with a 600x400 mm carrying surface of durable ABS plastic for transportation of plastic crates, cartons, etc.



Item No 1925057630



Item No 1925057631



Item No 1925057634

Shaped for Euroboxes

Item No 1925057632



Item No	1925057630	1925057634	1925057631	1925057632
Identification:	PD 250A	PD 250A	PD 250B	PD 250C
Capacity Kg:	250	250	250	250
External dimensions: LxWxH	602x425x165 mm	602x425x165 mm	605x403x170 mm	605x403x170 mm
Weight kg:	2.8	2.8	3.8	9
Wheel diameter mm	Nylon 100 mm, 4 swivel wheels	Nylon 100 mm, 2 fixed wheels and 2 swivel wheels	Nylon 100 mm, 4 swivel wheels	Nylon 100 mm, 4 swivel wheels

TRAY / CARTON TROLLEYS

Strong galvanised crate and carton trolleys suitable for heavy and frequent use.

Available in designs with loading area dimensions: 600 x 400 and 800 x 600 mm.

4 swivel wheels.

Item No 1925057644



Item No 1925057640



Item No	1925057640	1925057644
Identification:	ZD 400A	ZD 400B
Capacity Kg:	400	400
External dimensions: LxWxH	620x420x150mm	820x620x150 mm
Weight kg:	7	9.5
Wheels mm:	Nylon 100	Nylon 100



PLATFORM SCOOTER

For quick indoor transport of personnel and goods. Scooter with parallel steering and solid rubber wheels with ball bearings. Footplate with anti-slip protection and a powerful foot brake for the rear wheel. Wheels: 200 mm rubber.

Platform size 690x585 mm. Turning radius 1200 mm. Total loading capacity 150 kg (incl. driver).

- Adjustable steering wheel

Top Shelf 526x526 mm
Item No 1918058021



NEW

Writing Desk A4
Item No 1918058022



FlatPack

Item No 1918058020



Item No 1918058020 +
1918058021 + 1918058022



CLEANING TROLLEY

Cleaning trolley for indoor and outdoor use. Manufactured of a strong, powder coated tubular steel frame. The cleaning trolley has fittings for bin bags, two tube holders for cleaning equipment and a basket for storing bin bags, etc.

Item No 1910057007

Item No	1910057007
Identification	CT
Loading capacity Kg	200
Height mm	1120
Width mm	730
Bin bag holder diameter mm	400
Total Length mm	1118
Wheel diameter mm	400x100
Wheel type	Pneumatic
Weight kg	30



MECHANICAL TRANSPORTER

Superb tool for moving machinery, furniture, cupboards and other bulky or heavy goods. Raised and lowered easily and safely using a crank.

Supplied in sets of two, straps included.



Item No 1951049506

Item No	1951049506
Capacity kg / set	600
Lifting height mm	300
Load plate dimensions mm	225x120

HYDRAULIC TRANSPORTER

For moving heavy machinery and furniture such as tool cupboards, safes or other heavy, cumbersome goods. The quality gearing in the pump handle makes it easy to lift all types of goods. The rubber-coated loading surface and the large easy to roll polyurethane wheels protect your goods!

Intelligently designed handle for best ergonomics and highest user protection.

Supplied in sets of two, straps included.



Item No 1951049518

Item No	1951049518
Capacity kg / set	1800
Lifting height mm	250
Load plate dimensions mm	600x60

TRANSPORT CORNER

For simple moving of furniture, machinery and other rectangular goods. Equipped with a ribbed rubber surface to protect the goods during transport.

One set includes 4 corners.

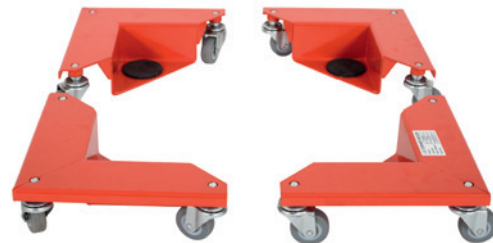

Item No 1951049000

Item No	1951049000
Capacity kg	600
External dimensions mm	366x204x85
Load height above the floor mm	15
Wheel dimensions mm	50x20
Weight kg/set	8

FLEXIBLE ROLLER CONVEYOR

The flexible roller conveyor is adjustable and can easily be adapted as required. Vertically adjustable. Wheels with brakes. The rollers are a bit higher than the track, which means that goods wider than the track can be handled.



Roller Stand
Item No 1211039002

Item No	1211039002
Capacity kg	75
Height adjustable mm	650-1065
Bearing Roller width mm	320
Bearing Roller diameter mm	35
Spring shaft diameter mm	6,35

Item No 1211039000



- Easy to assemble sections to achieve the desired length.
- Chrome-plated rollers 42 x 500 mm.
- Recessed 419 mm/section.
- 4 wheels with brakes Ø 100 mm.
- 9 rollers/section.

Item No	1211039000
Max length / section mm	1295
Loading capacity kg / section	136
CC roller / roller max extension mm	170
Distance between rollers mm	125
Adjustable height mm	660 - 940
Weight kg/set	27

MR200 DISPLAY TRUCK

Display truck for flexible use of 1/4 pallets. Mechanical raise/lower function with foot pedal.



Item No 1151041820

Item No	1151041820	1151041830
Capacity Kg	200	250
Min lift height mm	95	95
Max lift height mm	120	390
Fork length mm	580	580
Fork width mm	210	200
Overall length mm	880	910
Overall width mm	500	505
Handle height mm	1055	1025
Weight kg	21	40
Fork wheels mm	80 x 20 polyurethane	82 x 60 polyurethane

DISPLAY STACKERS

- The solution for stacking and moving display pallets
- This pallet truck provides a simple solution for handling 1/4 display pallets to and from a Euro pallet
- 2 steering castors
- 2 rubber bumpers ensure goods are set down gently
- Lifting and lowering via foot pedal



Item No 1151041830

Vi-Lift SERIES

Vi-lift, the strongest and widest hand pallet truck series in our range! Available with fork lengths from 650 mm up to 2500 mm, capacities from 2000 kg up to 3000 kg. This series includes painted and galvanised versions and also hand brake as an option for the 3000 kg heavy duty range for maximum safety! With Vi-lift there is always a solution for your need!



Item No 1125041630



Item No 1125041631



Item No 1125041632



Item No 1125041634



Item No 1130041606
With Hand Break!



Option: Foot Break
Item No 6212109443



Item No 1125041652



Capacity 5000kg!
Item No 1130041615

NEW

Item No	Capacity kg	Max lifting height mm	Min lifting height mm	Fork length mm	Fork width mm	Fork size mm	Steering wheel	Fork wheel mm	Weight Kg
1125041630	2500	200	80	1150	540	150x50	Poly 180x50	Poly/Bogie 80x70	65
1125041631	2500	200	80	1150	540	150x50	Nylon 180x50	Nylon/Single 95x75	58
1125041632	2500	200	80	650	540	150x50	Poly 180x50	Poly/Single 90x80	55
1125041633	2500	200	80	1150	540	150x50	Rubber 180x50	Poly/Bogie 80x70	62
1125041634	2500	200	80	800	540	150x50	Poly 180x50	Poly/Single 90x80	60
1125041635	2500	200	80	800	540	150x50	Nylon 180x50	Nylon/Single 90x80	55
1125041636	2500	200	80	1150	540	150x50	Nylon 180x50	Nylon/Bogie 80x70	58
1125041637	2500	200	80	1150	540	150x50	Poly 180x50	Poly/Single 90x80	65
1125041651	2500	200	80	1150	450	150x50	Poly 180x50	Poly/Bogie 80x70	65
1125041652	2500	200	80	800	450	150x50	Poly 180x50	Poly/Bogie 80x70	60
1130041602	3000	200	80	1150	540	150x50	Poly 180x50	Poly/Bogie 80x70	78
1130041606	3000	200	80	1150	540	150x50	Poly 180x50	Poly/Bogie 80x70	85
1130041615	5000	200	80	1150	540	150x50	Poly 180x50	Poly/Bogie 80x70	100

LONG FORK HAND PALLET TRUCKS

A new range of hand pallet trucks with long forks for handling of long goods or several pallets simultaneously. They are heavily reinforced to handle cargo up to 2 tons. They are equipped with polyuretane wheels to make it easier to get around on uneven ground as well as over smaller obstacles such as stone and debris that may be on the floor. Polyuretane wheels make the carriage quiet and smooth.

NEW

Item No 1130041604

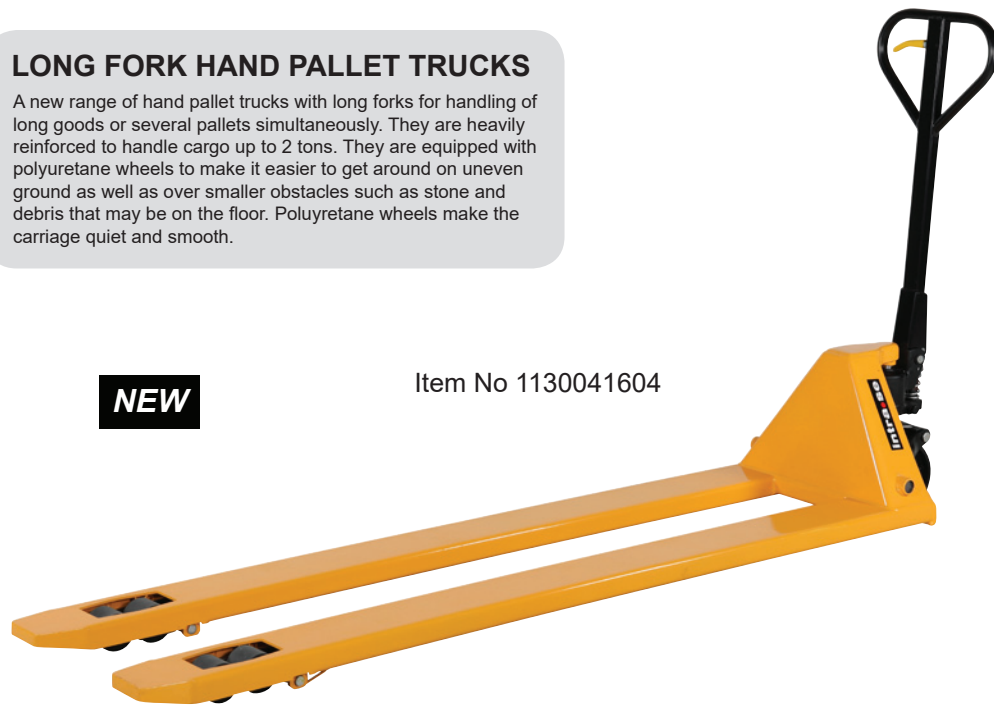

Item No	Capacity kg	Max lifting height mm	Min lifting height mm	Fork length mm	Fork width mm	Fork size mm	Steering wheel	Fork wheel mm	Weight Kg
1125041640	2000	200	80	1500	540	150x50	Poly 180x50	Poly/Bogie 80x70	85
1125041642	2000	200	80	2000	540	150x50	Poly 180x50	Poly/Bogie 80x70	102
1125041644	2000	200	80	2500	540	150x50	Poly 180x50	Poly/Bogie 80x70	115
1130041604	3000	200	80	2000	540	150x50	Poly 180x50	Poly/Bogie 80x70	110

PL 2500 QUICKLIFT

- Quicklift function works up to 150 kg
 - Lifts pallets in one pump stroke
 - Overload valve
 - Double climbing wheel
 - Rounded fork ends simplify the handling of all goods
 - Maintenance-free ball bearings
 - Turning radius of 230 degrees
 - Comfortable, coated handle
 - Available in several fork lengths and wheel alternatives
 - Quicklift is most suitable for lighter loads.
- Capacity 2500 kg.

Item No 1115040004



OPTION: FOOT BRAKE!
Item no 1130041299



Item No	Max lifting height mm	Min lifting height mm	Fork length mm	Fork width mm	Fork size mm	Steering wheel 200x50 mm	Fork wheel mm	Weight Kg
1115040001	200	85	1150	540	160	Nylon	Nylon/Single 80x93 mm	75
1115040002	200	85	1150	540	160	Nylon	Nylon/Bogie 80x70 mm	75
1115040003	200	85	1150	540	160	Rubber	Poly/Single 80x93 mm	75
1115040004	200	85	1150	540	160	Rubber	Poly/Bogie 80x70 mm	75
1115041001	200	85	900	540	160	Nylon	Nylon/Single 80x93 mm	70
1115041002	200	85	900	540	160	Nylon	Nylon/Bogie 80x70 mm	70
1115041003	200	85	900	540	160	Rubber	Poly/Single 80x93 mm	70
1115041004	200	85	900	540	160	Rubber	Poly/Bogie 80x70 mm	70
1115041011	200	85	800	540	160	Nylon	Nylon/Single 80x93 mm	68
1115041013	200	85	800	540	160	Rubber	Poly/Single 80x93 mm	68

HPT-A 2500

Professional and ideal transport help for all variety of manual transport tasks in stores and warehouses as well as factory plants. Reliable, sturdy, torsion-resistant due to its extremely strong high quality steel profile.

Item No 1125041033



Item No	1125041033
Capacity kg	2500
Fork length mm	1150
Fork width mm	540
Max lifting height mm	200
Min lifting height mm	85
Fork wheel mm	Bogie/Pu* 80x70
Steering wheel mm	Rubber 200x50
Weight kg	75

STOP IT

Unique stop-it brake in rubber that holds all types of pallet trucks in place during transport or simply keeps them in a permanent place in the workplace when they are not in use.

Dimensions mm: 310x310x40

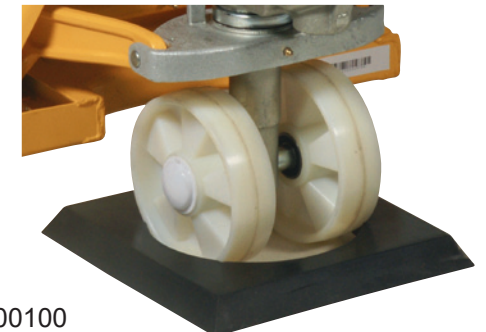

Item No 8710000100



GALVANIZED HAND PALLET TRUCK

The galvanised steel truck are designed for tougher environments.

Item No 1125041692

Item No	1125041692
Type	Galvanised
Capacity kg	2500
Min lifting height mm	80
Max lifting height mm	200
Fork length mm	1150
Total width mm	540
Fork width mm	160
Steering wheel 180x50	Nylon
Fork wheel (50x70 mm)	Nylon/Bogie
Weight kg	63

LOW PROFILE HAND PALLET TRUCKS

For handling of special pallets.

Item No	1140041607	1140041608
Capacity kg	1500	1000
Min lifting height mm	51	35
Max lifting height mm	175	95
Fork length mm	1150	1150
Total width mm	540	540
Fork width mm	160	160
Steering wheel	Polyurethane 180x50 mm	Polyurethane 180x50 mm
Fork wheel	Polyurethane/Bogie 50x70 mm	Polyurethane 35x44 mm
Weight kg	83	62

NEW

Item No 1140041607



STAINLESS HAND PALLET TRUCK

Stainless steel hand truck for the slightly tougher environments. 304 quality stainless steel.

Item No 1125041695

Item No	1125041695
Type	Stainless
Capacity kg	2500
Min lifting height mm	80
Max lifting height mm	200
Fork length mm	1150
Total width mm	540
Fork width mm	160
Steering wheel 180x50	Nylon
Fork wheel (50x70 mm)	Nylon/Single
Weight kg	63

ACW 20S WEIGHING TRUCK, ACCURATE

Tolerance: $\pm 0,05\%$
IP 5X
Battery: Rechargeable battery. Charger included.
Single climbing wheel.



Item No 1820042010

Item No	1820042010
Type	Weighing
Capacity Kg	2000
Min lifting height mm	88
Max lifting height mm	200
Fork width mm	542
Fork length mm	1150
Fork size	162
Fork wheel $\varnothing 74 \times 70$ mm	Pu*/Bogie
Steering wheel $\varnothing 180 \times 50$ mm	Rubber
Weight kg	110

SEMI STAINLESS AND STAINLESS HAND PALLET TRUCK

The stainless products is specially made for fishing, butchery - and pharmaceutical industries, places with high requirements for hygiene, environment and thorough cleaning. The pallet truck can be tailored after your requirements. As the pallet truck is made of stainless steel, this means that it can withstand most instances of moisture and cleaning chemicals. You can choose the stainless steel qualities between 304 and 316. Alternativ wheel options is available.

Item No	1145040206	1145040207
Type	Stainless Pallet Truck	Semi Stainless Pallet Truck
Capacity Kg	2000	2500
Min lifting height mm	85	85
Max lifting height mm	200	200
Total width mm	520	520
Fork length mm	1130	1130
Fork size	160	160
Fork wheel	Nylon/Single	Nylon/Single
Steering wheel	Nylon	Nylon
Weight kg	76	76

Item No 1145040206



ZF20 WEIGHING TRUCK, ACCURATE

Tolerance: $\pm 0,1\%$
IP 65
Battery: 4 pcs, AA / LR6 included!
Single climbing wheel.



Item No 1820042001

Item No	1820042001
Type	Weighing
Capacity Kg	2000
Min lifting height mm	85
Max lifting height mm	205
Fork width mm	555
Fork length mm	1150
Fork size	180
Fork wheel $\varnothing 74 \times 70$ mm	Pu*/Bogie
Steering wheel $\varnothing 180 \times 50$ mm	Rubber
Weight kg	117

PREMIUM QUALITY!
MADE IN SCANDINAVIA.

SCISSOR LIFT

Manual scissor lift with a telescopic cylinder.
Automatic quicklift, 38 mm/pump stroke up to 150 kg.
20 mm/pump stroke. 28-29 pump strokes to full height.

Above 150 kg the lift height per pump stroke is 20 mm.

Item No	1830043000	1830043015	1830043016
Piston type	Telescopic	Telescopic	Telescopic
Capacity Kg	1000	1000	1000
Min lifting height mm	85	85	85
Max lifting height mm	800	795	800
Fork width mm	540	540	540
Fork length mm	1150	1500	2000
Fork size	160	160	160
Fork wheel Ø 80 x 50 mm	Polyurethane	Polyurethane	Polyurethane
Steering wheel Ø 180 x 50 mm	Polyurethane	Polyurethane	Polyurethane
Weight kg	90	110	180

NEW

Item No 1830043000



2-step piston, automatic quicklift.
With a fork length of 1150 mm,
1500 mm or 2000mm.

STAINLESS SCISSOR LIFT

Rust-proof scissor lift for tough climates
and workplaces with high cleanliness
requirements. Stainless steel quality 304.

Item No	1830043002
Piston type	Telescopic
Capacity Kg	1000
Min lifting height mm	85
Max lifting height mm	800
Fork width mm	540
Fork length mm	1150
Fork size	160
Fork wheel Ø 80 x 100 mm	Nylon
Steering wheel Ø 180 x 50 mm	Nylon
Weight kg	90

2-step piston

Item No 1830043002



SCISSOR LIFT

Manual scissor lift with a single cylinder.

23 mm/pump stroke.

Item No	1830043020
Piston type	Single piston
Capacity Kg	1000
Min lifting height mm	85
Max lifting height mm	800
Fork width mm	540
Fork length mm	1150
Fork size	160x50
Fork wheel Ø 78 x 60 mm	Polyurethane
Steering wheel Ø 180 x 50 mm	Polyurethane
Weight kg	125

Item No 1830043020



SCISSOR LIFT ELECTRIC

The compact design with a
battery and a pump unit positioned
between the chassis and cylinder
provides superior manoeuvrability
and accessibility.

Often used as an ergonomic aid
for protecting the back, neck and
shoulders. Possible to both pump
and lower manually if the battery is out of
power.
Lift without load - 11 sec.
Lift with load - 19 sec.

NEW

Item No 1832043012



Item No	1832043010	1832043012	1832043013
Piston type	Single piston	Single piston	Single piston
Capacity Kg	1000	1000	1500
Min lifting height mm	85	85	85
Max lifting height mm	800	800	800
Fork width mm	540	540	540
Fork length mm	1170	2000	1170
Fork size	160	160	160
Fork wheel Ø 50 x 75 mm	Polyurethane	Polyurethane	Polyurethane
Steering wheel Ø 180 x 50 mm	Polyurethane	Polyurethane	Polyurethane
Weight kg	169	220	170

Electric scissor lift, single
piston. Battery 12v/70 Ah.
Built-in charger 5 A /12 V
Operating voltage of 220 V.

LIFTING TABLE PL LBM

Manual lifting table, height adjustable with the crank. Two fixed wheels and two castors. Also available with four swivel wheels. Add art.no 8611012834.



Item No	1860050301	1860050302
Identification	PL LBM	PL LBM Large
Capacity Kg	300	300
Min lifting height mm	410	410
Max lifting height mm	1050	1050
Carrying surface mm	950x600	1150x750
Total length with crank mm	1150	1300
Total length without crank mm	1050	1200
Load plate	Steel	Steel
Wheel Ø rubber	125	125
Cycles to max height	75	75
Weight kg	70	77

LIFTING TABLE MANUAL

Hydraulic lifting table in four versions. Load capacity of 150 to 1000 kg. The lifting is easily adjusted with a foot pump and the lowering with a manual hand lever control. Two fixed wheels and two castors.

Item No	1860051015	1860051030	1860051050	1860051055	1860051075	1860051100
Identification	SP150	SP300	SP500	SP500B	SP750	SP1000
Capacity Kg	150	300	500	500	750	1000
Min lifting height mm	225	340	355	310	420	380
Max lifting height mm	740	900	900	1100	1000	1000
Carrying surface mm	740x450	855x500	855x500	1200x800	1000x510	1016x515
Load plate	Electro zink plated	Electro zink plated	Electro zink plated	Electro zink plated	Electro zink plated	Electro zink plated
Wheel Ø polyurethane	100	125	125	127	150	150
Pumps to max height	25	32	45	80	70	55
Handle	Foldable	Fixed	Fixed	Fixed	Fixed	Fixed
Handle height mm	935	970	970	970	996	962
Weight kg	44	82	87	120	115	115



Item No 1860051030

NEW



Item No 1860051055

LIFTING TABLE MANUAL

Hydraulic lifting table with double scissors. The raising is easily adjusted with a foot pump and the lowering with a manual hand lever control. Two fixed wheels and two castors.

Item No	1860051035	1860051070
Identification	SPS350	SPS800
Capacity Kg	350	800
Min lifting height mm	350	475
Max lifting height mm	1300	1500
Carrying surface mm	910x500	1220x610
Load plate	Electro zink plated	Electro zink plated
Wheel Ø polyurethane	125	150
Pumps to max height	60	70
Handle	Fixed	Fixed
Handle height mm	970	962
Weight kg	105	172



Item No 1860051070

LIFTING TABLES STAINLESS STEEL

Stainless structure ideal for handling pharmaceutical, food, beverage etc. Dual brakes for added safety. Robust structure yet light weight.

On 1860050305 the height is adjusted by the crank.

On 1860055050 the height is adjusted by the foot pump and lowered by the hand lever control.

Item No	1860050305	1860055050
Identification	MLT300	BSS50
Capacity Kg	300	500
Min lifting height mm	440	442
Max lifting height mm	1000	1000
Length mm	1150	1270
Width mm	600	520
Carrying surface mm	950x600	1010x520
Load plate	Stainless Steel #304	Stainless Steel #304
Wheel Ø polyurethane	125	150
Cycles to max height	75	22
Handle	-	Fixed
Handle height mm	-	1100
Weight kg	70	123

Item No 1860050305



Item No 1860055050



LIFTING TABLE ALUMINUM

Aluminum light weight for easy handling and easy to fold.



Item No 1860055010



Item No	1860055010
Identification	ALT10
Capacity Kg	100
Min lifting height mm	265
Max lifting height mm	755
Carrying surface mm	450x700
Load plate	Aluminum
Wheel Ø polyurethane	100
Cycles to max height	35
Handle	Foldable
Handle height mm	1000
Weight kg	26

STATIONARY LIFTING TABLES

Electric lifting tables for best ergonomics and working environment. The stationary electro-hydraulic lifting tables are suitable for all types of work and installations. Very useful in the industry and warehouses. Welded bottom frame and integrated hydraulics.

1321053150 & 1321053200 are equipped with two hydraulics.

We recommend to fix the table on the ground!

Item No 1321053150



Item No	1321053100	1321053102	1321053150	1321053200
Identification	PLN 1000	PLN 220V	PLN 2000	PLN 3000
Capacity Kg	1000	1000	2000	3000
Min table height mm	190	205	235	235
Max table height mm	1010	990	1010	1010
Carrying surface mm	1300x800	1300x820	1300x800	1300x800
Lifting speed loaded mm/sec	25	28	25	30
Power supply	400 V/16A	220 V/50Hz	400 V/16A	400 V/16A
Hydraulic motor	1.1 kW	1.1 kW	1.5 kW	2.2 kW
Weight kg	160	160	235	280
External dimensions underframe mm	1255x680	1240x747	1255x735	1255x735

- Simple control unit
- Safety frame

LIFTING TABLES ELECTRIC

Electric lifting tables on wheels. The tables is lowered and raised with hand control. Two fixed wheels and two castors. Foot protection on the swivel wheels and brakes!

1865052055 if perfect table size for handling EU-pallets.

Item No	1865052050	1865052052	1865052055
Identification	PL 500-LB EL	ES50D 500-LB EL	PL 1000-LB EL
Capacity Kg	500	500	1000
Min lifting height mm	450	495	430
Max lifting height mm	950	1618	1220
Carrying surface mm	1010x520	1010x520	1200x800
Load plate	3 mm chrome-plated steel	3 mm chrome-plated steel	3 mm chrome-plated steel
Wheel Ø polyurethane	150	150	150
Handle	Fixed	Fixed	Fixed
Handle height mm	1180	1180	1180
Power pack	700W	700W	700W
Battery	70Ah/12V	75Ah/12V	75Ah/12V
Charger	Built in 24V4A	Built in 24V4A	Built in 24V4A
Weight kg	148	198	225

STATIONARY LIFTING TABLES

Electric lifting tables for best ergonomics and working environment. The stationary electro-hydraulic lifting tables are suitable for all types of work and installations. Very useful in the industry and warehouses. Welded bottom frame and integrated hydraulics.

We recommend to fix the table on the ground!

Item No	1321053050	1321053110
Identification	HW500L	HW1005
Capacity Kg	500	1000
Min table height mm	200	240
Max table height mm	1000	1300
Carrying surface mm	2000x800	2000x850
Lifting speed loaded mm/sec	25	35
Power supply	380 V/50 Hz	380 V/50 Hz
Hydraulic motor	1,1 kW	1,1 kW
Weight kg	193	252
External dimensions underframe mm	1615x680	1615x787

NEW

- Simple control unit
- Safety frame



Item No 1865052050

NEW



Item No 1865052055

Item No 1321053110



STATIONARY LONG LIFTING TABLE

Long scissor table that is designed to handle very large and heavy goods. Thanks to double scissor sections, the table becomes both more stable and more durable for the extra heavy lifts. The table is perfect for warehouses, logistics centers and production halls where a little extra is required.

We recommend to fix the table on the ground!

- Simple control unit
- Safety frame

Item No	1321053160
Identification	HW2000D
Capacity Kg	2000
Min table height mm	205
Max table height mm	1000
Carrying surface mm	2500x820
Lifting speed loaded mm/sec	16
Power supply	400 V/16A
Hydraulic motor	1.5 kW
Weight kg	265
External dimensions underframe mm	2470x680



Item No 1321053160

STATIONARY HIGH LIFTING TABLE

The obvious choice for high lifts in production halls and warehouses. The table is equipped with an overflow valve and a safety protection frame for the user's safety. Simple control unit. We recommend to fix the table on the ground!

Item No	1321053120
Identification	HD1000
Capacity Kg	1000
Min table height mm	305
Max table height mm	1780
Carrying surface mm	1300x820
Lifting speed loaded mm/sec	35
Power supply	400 V/16A
Hydraulic motor	1.5 kW
Weight kg	210
External dimensions underframe mm	1255x680



Item No 1321053120

STATIONARY U-SHAPED LIFTING TABLE

Electric lifting table for best ergonomics and working environment.

Stationary electro-hydraulic U-shaped lifting table which is suitable for all types of work and installations. Very useful in the industry and warehouses. Welded bottom frame and integrated hydraulics.

We recommend to fix the table on the ground!

- Simple control unit
- Safety frame

Item No	1321054100
Identification	U-shaped lifting table
Capacity Kg	1000
Min table height mm	85
Max table height mm	760
Carrying surface mm	1450x1140
Lifting speed loaded mm/sec	42
Lowering speed loaded mm/sec	48
Power supply	400 V/16A
Hydraulic motor	1.5 kW
Weight kg	235
External dimensions underframe mm	1340x1070

Item No 1321054100



STATIONARY LIFTING TABLE WITH RAMP

Electric lifting table for best ergonomics and working environment.

Stationary electro-hydraulic lifting tables with ramps which are suitable for all types of work and installations. Very useful in the industry and warehouses. Welded bottom frame and integrated hydraulics.

We recommend to fix the table on the ground!

- Included ramp
- Simple control unit
- Safety frame

Item No	1321053250
Identification	Lifting table with ramp
Capacity Kg	1000
Min table height mm	85
Max table height mm	760
Carrying surface mm	1450x1140
Lifting speed loaded mm/sec	42
Lowering speed loaded mm/sec	48
Power supply	400 V/16A
Hydraulic motor	1.5 kW
Weight kg with ramp	350
External dimensions ramp mm WxB	1140x885

Item No 1321053250



LIGHT LIFTER

Light, flexible and easily manoeuvred lifting truck with a load plate as a standard design. Designed to relieve the back and shoulders in connection with all types of lifting.

Available in 4 models with a capacity of 100, 150 or 250 kg and in different lifting heights.

Equipped with Ø 75-mm swivel fork wheels and Ø 125-mm wheels with brakes.



Item No
1843044048

Item No	1843044040	1843044042	1843044043	1843044048
Identification	E100A	E150A	E250N	E100NS
Capacity Kg	100	150	250	100
Lifting height mm	1700	1500	1800	2000
Lifting speed unloaded/loaded	83/70 mm/s	83/70 mm/s	83/70 mm/s	83/70 mm/s
Lowering speed unloaded/loaded	85/101 mm/s	85/101 mm/s	85/101 mm/s	85/101 mm/s
Battery	24V/12Ah	24V/12Ah	24V/20Ah	24V/20Ah
Lifting motor	24 V drive motor	24 V drive motor	24 V drive motor	24 V drive motor
Load plate mm	600x470	600x470	610x480	600x470
Load plate material	Plastic	Plastic	Steel	Plastic
Fork wheel Ø mm Polyurethane	75	75	75	75
Steering wheel Ø mm Polyurethane	125	125	125	125
Weight kg	66	64	90	68
Total height mm	1990	1790	2220	2290
Total width mm	600	600	740	600
Total length mm	870	870	870	870



Roll turner Item No 1233044046

ACCESSORIES

Single roll pike:
Ø 47 mm, length 600 mm.

Double roll pike:
Ø 47 mm, length 450 mm.

V block:
400x400 mm, maximum height 80 mm

Roll turner:
Maximum size Ø 500 mm and depth 250 mm. Inner Ø 74-80 mm.

V-Block Item No 1233044047

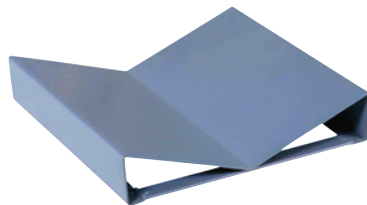

Double carpet boom Item No 1233044045

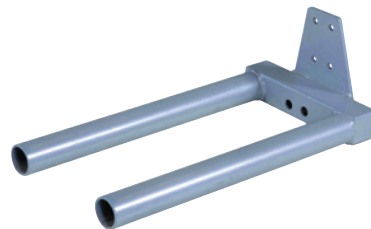

Single carpet boom Item No 1233044044



LIGHT LIFTER

Light, flexible and easily manoeuvred lifting truck with a loading plate and forks underneath. It takes care of those lifts that are "harmful" to the body. Powerful when needed but occupies little space when not in use.

Suitable for many different applications in pharmacies, libraries, kitchens, shops, warehouses, the workshop industry, etc. Supplied with an external charger (charging capacity 24V/1.8 Ah), operating voltage 220 V.

Item No	1843044000
Identification	LV-150
Capacity Kg	150
Lifting height mm	1550
Lifting speed loaded	125 mm/sec
Lowering speed unloaded/loaded	85/101 mm/s
Battery	7 Ah/12V x 2
Lifting motor	24V drive motor
Load plate mm	460x520
Fork wheel Ø mm Polyurethane	75x32
Steering wheel Ø mm Polyurethane	100x32
Weight kg	58
Total height mm	1940
Total width mm	520
Total length mm	880

Item No 1843044000



MINI STACKER MANUAL OR ELECTRIC

Hydraulic stacker and mobile lifting table equipped with both forks and a detachable platform. Manual stacker with a foldable pump lever for lifting and a manual handle for lowering. The electrical stacker has a large battery and a built-in charger.



Item No 1840044110



Item No 1841044211

Item No	1840044080	1840044110	1840044115	1841044211	1841044215
Identification	PL-800 HST	PL-1100 HST	PL-1500 HST	PL-1100 HST-EL	PL-1500 HST-EL
Capacity Kg	400	400	400	400	400
Lifting height mm	85-850	85-1200	85-1500	85-1200	85-1500
Lifting speed loaded	20	20	20	80 mm/sec	80 mm/sec
Battery	-	-	-	12V/60Ah	12V/60Ah
Lifting motor	-	-	-	700 W	700 W
Fork width mm	550	550	550	550	550
Fork length mm	650	650	650	650	650
Fork wheel Ø mm Polyurethane	75x40	75x40	75x40	75x40	75x40
Steering wheel Ø mm Polyurethane	127x40	127x40	127x40	127x40	127x40
Weight kg	75	81	91	118 incl. battery	126 incl. battery
Total height mm	1074	1425	1725	1425	1725
Total width mm	600	600	600	600	600
Total length mm	1035	1035	1035	1100	1100

BALDER STACKER MANUAL OR ELECTRIC

A compact stacker of a stable design with ergonomic tilt. The pallet is raised to the correct work height and the sideways tilt makes the work comfortable and ergonomic. Available in manual and electric versions. The tilt is manual on both types. The design is very compact and is suitable for narrow spaces. Brakes on both wheels.

Item No	1840045510	1841045511
Identification	Ergo – Manuell	Ergo - EL
Capacity Kg	800	800
Lifting height mm	900	900
Lifting capacity / during tilting:	800/400	800/400
Total height mm	1230	1420
Total width mm	730	730
Total length mm	1630	1690
Fork length mm	1140	1140
Width above forks mm	540	540
Fork width mm	150	150
Fork height lowered mm	87	87
Weight kg	218	230 (without battery)
Swing radius mm	1500	1500
Lifting height/pump stroke loaded	18 mm -	-
Steering wheel mm	200x50	200x50
Fork wheel mm	82x90	82x90
Tilt angle	40°	40°
Battery	-	2x12 V / 60 Ah
Charger		External 10A/12V
Lifting speed with load	18 mm per pump stroke	50 mm /sec
Hydraulic motor	-	700 w / 12 V

MANUAL TILT



TILT ANGLE 40°



Item No 1841045511



Item No 1840045510



MANUAL STACKERS

Strong, robust and ergonomically designed stacker with a foot pump, protects both the back and the shoulders. It is also possible to use the handle to pump up the forks. The stackers are built for professional use and supplied with a foot brake on both wheels.

- Fork wheel & Steering wheel = Nylon

Item No	1840043101	1840043161	1840043251	1840043300
Identification	PL 1000 ST	PL 1600 ST	PL 2500 ST	PL 3000 ST
Capacity kg	1000	1000	1000	1000
Min lifting height mm	80	80	80	85
Max lifting height mm	1000	1600	2500	3000
Total height max mm	1425	1990	3025	3525
Total height min mm	1425	1990	1833	2060
Total width mm	800	800	800	800
Total length mm	1700	1700	1700	1700
Fork length mm	1150	1150	1150	1150
Fork width mm	170	170	170	170
Overall Fork width mm	550	550	550	550
Fork wheel Ø mm	Single 80 x 70	Single 80 x 70	Single 80 x 70	Single 80 x 70
Weight kg	183	204	280	315

NEW

Item No 1840043101



Item No 1840043251



SEMI ELECTRIC STACKERS

Manually moved stackers with a battery-powered lifting motor. Ergonomic handling for frequent heavy lifts. The stacker is completely adapted to its work tasks. Loading and unloading, as well as stacking of palletized goods. The powerful battery provides a long operating time per charge. Foot brakes on both steering wheels. Easy-to-service construction of the hydraulics, distribution box and battery.

- Efficient and ergonomic lifting tool.
- Supplied complete with a battery and charger.
- Easy-to-read battery indicator for control of the capacity of the battery.

Item No	1841043085	1841043166	1841043256	1841043356
Identification	PL 800 ST-EL	CDD 10B-III 1,6m	CDD 10B-III 2,5m	CDD 10B-III 3,3m
Capacity kg	1000	1000	1000	1000
Lifting height max mm	800	1600	2500	3300
Lifting height min mm	90	90	90	90
Total height max mm	1200	2090	3060	3797
Total height min mm	1200	2090	1840	2090
Total width mm	770	800	800	800
Total length mm	1720	1678	1678	1678
Fork length mm	1150	1150	1150	1150
Fork width mm	160	170	170	170
Fork height mm	56	60	60	60
Overall fork width mm	560	580	580	580
Battery	12V/85 Ah	12V/120 Ah	12V/120 Ah	12V/120 Ah
Charger	12V/20Ah	12V/15Ah	12V/15Ah	12V/15Ah
Fork wheel Ø mm nylon	Bogie 82x80	Single 80x78	Single 80x78	Single 80x78
Weight kg incl. battery	300	400	460	490

Item No 1841043256



Item No 1841043085



ELECTRIC PALLET TRUCKS PTE15Q 2 ATOM / PTE15N EDGE / PTE15NSC EDGE WITH SCALE

Full electric pallet trucks with easily exchangeable battery. Small like a normal manual hand pallet truck. It protects the body from damages thanks to its protection frames. With support wheels on the sides to prevent the truck to become unstable during transport of goods with a high gravity.

NEW

Item No	1415045111	1415045117	1415045217
Identification	PTE15Q 2 / Atom	PTE15N / Edge	PTE15NSC / Edge with scale
Capacity Kg	1500	1500	1500
Min fork height mm	85	85	85
Lifting height mm	195	195	195
Fork width mm	550	540	540
Total width mm	550	574	574
Fork length mm	1150	1150	1150
Total length mm	1580	1530	1530
Battery V/Ah	Li-ion 24/20	Li-ion 24/20	Li-ion 24/20
Charger	External	External	External
Weight kg incl. battery	114	123	180



Item No 1415045217



Scale with printer
Tolerance : ± 0,2%



PIN-code or
key required
to operate

ELECTRIC STACKERS EDGE WITH LITHIUM BATTERY

Edge electric stackers with lithium batteries bring a host of benefits to your business. From improved performance and efficiency to environmental sustainability and reduced maintenance, these advanced machines provide a competitive edge for material handling operations. Embracing this cutting-edge technology unlocks new levels of productivity and operational excellence.

Item No	1615045114	1615045115	1616045113	1616045123
Identification	PS12N 2900 EDGE	PS12N 3600 EDGE	PS12ND 1600 EDGE	PS12N 1600 EDGE
Capacity Kg	1200	1200	1200	1200
Min fork height mm	86	86	86	86
Lifting height mm	2900	3600	1600 / 185	1600
Min support height	1930	2280	1970	1930
Max support height	3337	4037	2075	1930
Free lift mm	70	70	1530	1530
Fork width mm	570	570	570	570
Fork length mm	1150	1150	1150	1150
Truck battery	Li-ion 60Ah/24V	Li-ion 60Ah/24V	Li-ion 60Ah/24V	Li-ion 60Ah/24V
Charger	Built-in	Built-in	Built-in	Built-in
Weight kg including battery	566	596	555	481

ELECTRIC STACKER MONOMAST

Electric stacker with single mast for a better sight and better safety. Embracing this cutting-edge technology unlocks new levels of productivity and operational excellence.

Item No	1613045616
Identification	PS12NM Monomast
Capacity Kg	1200
Min fork height mm	86
Lifting height mm	1600
Min support height	1930
Free lift mm	70
Fork width mm	570
Fork length mm	1150
Truck battery	Li-ion 60Ah/24V
Charger	Built-in
Weight kg including battery	480



Item No 1613045616



PIN-code or
key required
to operate

NEW

Item No 1616045113



With initial lift



PIN-code or
key required
to operate

Item No 1615045114



NEW

ELECTRIC STACKER PSE10L-C

PSE10L-C is an economic walkie-electric stacker, the compact and light design is suitable for a variety of low duty applications in warehouses.

Item No	1615045007	1615045008	1615045009
Identification	PSE10L 1,6	PSE10L 2,9	PSE10L 3,6
Capacity Kg	1000	1000	1000
Min fork height mm	87	87	87
Lifting height mm	1600	2900	3600
Min support height	2057	1982	2282
Max support height	2057	3389	3989
Free lift mm	1600	70	70
Fork width mm	570	570	570
Fork length mm	1150	1150	1150
Truck battery	80Ah/24V	80Ah/24V	80Ah/24V
Charger	Built-in	Built-in	Built-in
Weight kg including battery	450	510	570

NEW

Item No 1615045008



TE10 ELECTRIC TOW TRACTOR

To tow and pull different types of trolleys and other wheeled goods. Four different connections follows in each delivery.



QR-code
Link to
instruction
video

Item No	1418048100
Identification	TE 10
Capacity towing Kg	1000
Axle loading, unladen front/rear kg	46/16
Driving speed with/without load km/h	4.2/4.5
Height of tiller in driving position min/max mm	750/1250
Drive motor	0.3 kW
Drawbar Pull unladen N	200
Max. Drawbar Pull unladen N	450
Battery	24Ah
Charger	Extrenal
Tire size rear Ø mm Polyurethane	75 x 80
Drive wheel Ø mm	250 x 80
Total width mm	460
Weight kg incl. battery	62



Item No 1418048100

ELECTRIC STACKER WITH PLATFORM

Unleash efficiency and power in your warehouse with the PTE15C Electric Pallet Stacker with platform. This versatile electric stacker delivers exceptional performance, handling heavy loads effortlessly.

NEW



Item No	1613045632	1613045636
Identification	PSE15-C 3200	PSE15-C 3600
Capacity Kg	1500	1500
Min fork height mm	85	85
Lifting height mm	3200	3600
Min support height	2080	2280
Max support height	3605	4005
Free lift mm	78	78
Fork width mm	570	570
Fork length mm	1150	1150
Truck battery	2x12V / 106 Ah	2x12V / 106 Ah
Charger	Built-in	Built-in
Weight kg including battery	835	865

Item No 1613045632

STRONG COLLISION / MACHINE PROTECTION

To protect the workplace, machines, pallet racks, etc. Block or mark. As standard they are painted yellow to ensure the best visibility.

Item No 2533033001



Item No 2533033002



Item No	2533033001	2533033002	2533033003	2533033004
Identification	High-profile protection 01	Low-profile protection	Post	High-profile protection 04
Material	Steel	Steel	Steel	Steel
Height mm	1060	230	915	1100
Length mm	1220	1220	114	1000
Mounting plate mm	203x203	203x203	203x203	150x1000
Pipe mm (Diameter)	114	114	114	45
Weight kg	47	27	27	35

Item No 2533033003



NEW

Item No 2533033004



FORK EXTENSIONS BLACK OR GALVANIZED WITH COVERED BOTTOM

Strong truck forks with covered bottoms and pin for locking to the truck. Recommended for frequent use.

Item No	2520032006	2520032007	2520032008	2520032009
Fork extensions for max LxHxW mm	1800x45x100	2200x45x100	1800x45x125	2200x45x125
Weight kg	40	50	50	60
Capacity kg	2,5	2,5	4	4



Item No 2520032007

Item No	Fork extensions, length mm	Inside width in fork pockets mm	Suitable for fork size mm	Weight kg	Capacity ton
2520032215	1800	115	40x100	45	2,5
2520032216	2000	115	40x100	50	2,5
2520032227	2200	115	40x100	55	2,5
2520032217	2500	115	40x100	66	2,5
2520032218	2000	135	40x120	61	3
2520032225	2200	135	40x120	72	3
2520032219	2000	140	50x125	73	4
2520032220	2200	140	50x125	80	4
2520032221	2500	140	50x125	91	4
2520032222	3000	140	50x125	141	5
2520032223	2000	165	60x150	112	7
2520032228	2200	165	60x150	125	7
2520032224	2500	165	60x150	166	7
2520032231	3000	165	60x150	153	8
2520032229	2500	165	70x150	176	11
2520032230	3100	165	70x150	222	11



Item No 2520032218

CRANE FORKS

Self-balancing crane forks for handling of pallets with cranes, hoists, winches, etc. Both models have adjustable support heights and fork widths to suit all needs. The max goods height can be set at between 1300 and 2000 mm.



Item No 1221046030

Item No	1221046015	1221046030
Identification	CY 15	CY 30
Capacity kg	1500	3000
Fork length mm	1000	1000
Fork width mm	Adjustable in 5 steps from 350 to 900 mm.	Adjustable in 5 steps from 450 to 900 mm.
Lifting eye height mm	Adjustable in 3 steps from 1655 to 2355 mm.	Adjustable in 3 steps from 1720 to 2420 mm.
Automatic setting minimum load kg	300	600
Weight kg	165	280

WORK CAGES

For safe personal lifts. Provided with anti-slip floors, double safety chains to the locking pin and spring lock on the gate. The cages meet the requirements of the Swedish standards according to SS 3628. A first time inspection of cage and truck must be carried out by an accredited company according to AFS 1993:1. Powder coated.

Item No	1250065001	1250065002	1250065003
Size mm	800x800	1200x800	1200x1200
Total height mm	1990	1990	1990
Number of persons	1	1	2
Permitted total weight kg	200	250	500
Weight kg	60	80	110

Item No 1250065002

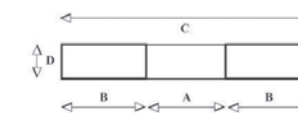

Fork channel internal dimensions:
A=195 mm, B=220 mm, C=670 mm,
D=75 mm.

FOLDABLE WORK CAGE

Practical, foldable lift cage. Assembled by one person in less than 30 seconds. The cage has an anti-slip floor. Equipped with fork locks to ensure the highest level of safety. Equipped with two wheels for simple and quick moving without a truck.



Item No 1250065010



Item No	1250065010
Total lifting capacity kg	300
Length x Width mm	1000x1000
Height collapsed mm	350
Height during use mm	1960
Weight kg	100

FORK TRUCK CRANE

Practical truck crane for lifting heavy machinery, moving motors, etc. The crane can be adjusted vertically to 40° in three positions from the horizontal one. Total length with the arm extended is 3500 mm. Total width is 500 mm. Fork tunnels internal – 160x60 mm. Equipped with a fork lock.

Item No 1221046010



Item No	1221046010
Fork tunnels internal dimensions mm	160x60
Length between mm	2220 - 3500
Capacity between kg	2300 - 440
Total width mm	500
Weight kg	204

FORK TRUCK CRANE

Converts a forklift truck into a mobile hoisting crane in a couple of seconds. Equipped with a fork lock and a catch to ensure the highest level of safety.

Item No	1221046008
Fork tunnels internal dimensions mm	180x60
Length between mm	2138 - 3741
Capacity between kg	3000 - 606
Total width mm	460
Total height mm	324
Weight kg	160

Item No 1221046008



LIFTING BLOCK

Strong lifting blocks for truck forks. Quickly transforms a fork lift truck into a mobile crane. Adjustable along the length of the forks. Attaches to the forks with a screw handle. The hook is fixed and equipped with a catch.

Item No 1221046044

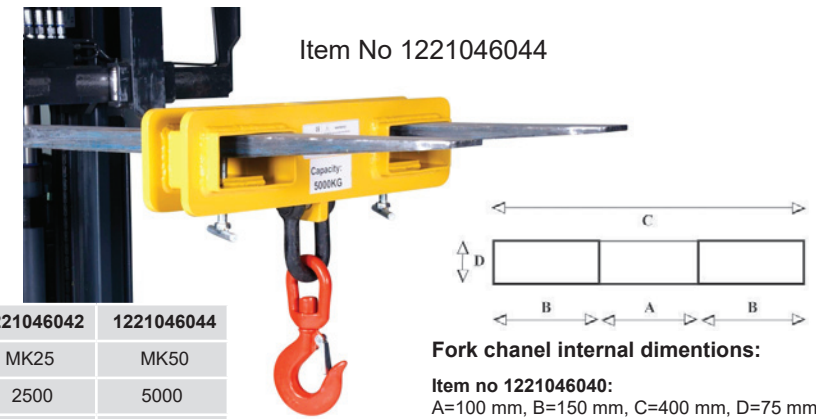

Item No	1221046040	1221046042	1221046044
Identification	MK10	MK25	MK50
Capacity Kg	1000	2500	5000
Max fork dimension mm	135x50	145x60	185x75
Weight kg	14	26	49

Fork chanel internal dimenstions:

Item no 1221046040:
A=100 mm, B=150 mm, C=400 mm, D=75 mm.
Item no 1221046042:
A=290 mm, B=160 mm, C=610 mm, D= 80 mm.
Item no 1221046044:
A=250 mm, B=200 mm, C=650 mm, D=100 mm.

WORKSHOP CRANE

- Quicklift/double acting pump.
- (Applies to Item No 1221046000).
- Chrome-plated piston.
- Safety valve.
- Easy to move.
- Easily foldable for flexible storage
- (Applies to Item No 1221046000).

Item No 1221046000



Item No	1221046000	1221046005
Lifting capacity in 3-4 positions kg	700-800-1000	700-800-900-1000
Boom length in 3-4 positions mm	1230-1380-1530	1540-1760-1980-2200
Boom height mm	0 -2450	0 -2400
Weight kg	150	103

Item No 1221046000
When folded

Item No 1221046005

Suitable for Euro Pallets.
Width between forks 840mm.



HYDRAULIC JACKS

Powerful tool for heavy lifting. Equipped with a practical handle. Available in two versions, with a capacity of 3 or 8 tonnes. The lifting claw is adjustable in three positions. Low minimum height for the lifting claw. The TG series is extremely suitable for all types of service and installation work of machinery.

Item No	1340057753	1340057754
Identification:	TG 30	TG 80
Capacity:	3 TON	8 TON
Lifting/stroke mm	140	140
Minimum lifting height mm	15	20
Maximum lifting height mm	155	160
Weight kg:	21.5	28



Item No 1340057753

RACK AND PINION JACK

Equipped with strong housing construction and stable footplate. Manufactured in hardened materials. The jacks are designed so that both the lifting claw and the crown (the top) can be used for lifting. Foldable crank makes transport and storage easy.

Item No	1340057740	1340057742
Capacity tonne	3	10
Lifting height claw mm	70-425	85-495
Lifting height top mm	730-1090	800-1210
Total height mm	730	800
Weight kg	21,2	46,8

Item No 1340057740



Item No 1340057742



MACHINE JACK

Strong and robust jacks for the heaviest lifting of machinery etc. 2-position lifting, either from the claw or the top. Equipped with a handle and wheels for simple and quick moving. The TB series is extremely suitable for all types of service and installation work of machinery.

Item No	1340057756
Identification:	TB 200
Lifting capacity claw	12 TON
Lifting capacity top	15 TON
Lifting/stroke mm	140
Lifting height top mm	325-545
Lifting height claw mm	40-260
Weight kg	69

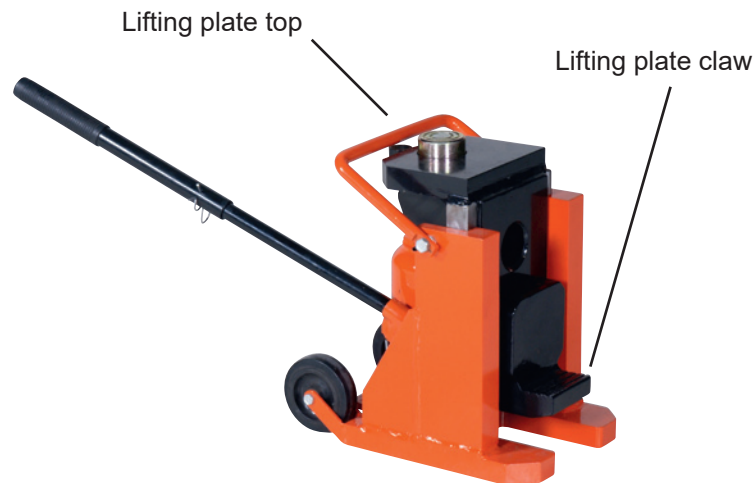

SUPPORT STANDS

Strong support stands with 3 height positions. Suitable, for lifting of forklift trucks, heavier machinery, etc. Sold in pairs.

Item No	2531057764	2531057766
Identification	HT-6	HT-9
Capacity	12 TON/Pair	18 TON/Pair
Lifting height mm	242-420	242-415
Weight kg	20	40

Item No 2531057764



Item No 2531057766



HYDRAULIC JACKS

Strong highcapacity jacks. Extra low lifting height with 2-position lifting claw in order to be able to gain access to places which are low. Equipped with wheels for simple and quick moving.

Item No	1340057760	1340057762
Identification:	HFJ-400	HFJ-700
Capacity:	4 TON	7 TON
Maximum lifting height mm	430	420
Minimum lifting height mm	65	65
Width mm	203	250
Weight kg	35	53

Item No 1340057760



Item No 1340057762



HYDRAULIC JACK UNIVERSAL

Compact, flexible, extra low and reliable design. It lifts with the lift foot or the top of the lift body. The body can rotate 360 degrees, which makes it unique. Jack Universal is suitable for all types of repair, maintenance and installation work. Stepless lowering speed and overload protection.

Item No	1340057750
Capacity ton	10
Lifting height foot mm	30-260
Lifting height top mm	420 -650
Weight kg	35

Item No 1340057750



WHEELED HAND LEVER

Long and strong wheeled hand lever. Manual lifter on wheels which lifts the goods the first couple of millimetres from the floor level so as to enable the use of a hydraulic jack or machine rollers.



Item No 1951057700

Item No	1951057700
Capacity TON	1.5
Length mm	2000
Weight kg	13
Wheel diameter mm	100
Wheel width mm	55
Wheels	Steel

MACHINE ROLLERS

Powerful machinery transporters for handling of heavy goods weighing between 2 and 24 tonnes. All of them have a loading surface covered in rubber to protect the transported goods. Models with towing rods have a swivel wheel and the carrying plate follows the direction of the tow road for flexible and safe movement. Sold separately.



Item No 1951057702

Item No 1951057712



Easy to connect to each other both on the short and long side.

MACHINE ROLLERS

Strong and flexible machine rollers for handling of heavy goods weighing between 2 and 24 tonnes. All of them have a loading surface covered in rubber to protect the transported goods.

CM60-N can be set at between 500 and 1400 mm. CM60-N and CM240-N can be set at between 720 and 1500 mm.

Supplied in sets where each set consists of two machine rollers and two steel rods.

Item No	1952057726	1952057728	1952057730
Identification:	CM60-N	CM120-N	CM240-N
Capacity:	2x3 TON	2x6 TON	2x12 TON
Number of wheels:	8	12	16
Wheels:	Polyurethane 90x85	Polyurethane 90x85	Steel 85x83
Dimensions: LxWxH	300x250x115	360x220x115	360x220x115
Weight kg:	30	38	65

Item No	1951057702	1951057704	1951057706	1951057712	1951057724
Identification:	AS20-N	SS40-P	SS60P	AS120-N	SS240-P
Capacity:	2 TON	4 TON	6 TON	12 TON	24 TON
Loading plate:	Fixed	Turnable	Turnable	Fixed	Turnable
Number of wheels:	2	4	8	8	16
Wheels	Nylon 82x100 mm	Polyurethane 82x100 mm	Polyurethane 82x100 mm	Nylon 115x60 mm	115x60 mm Polyurethane
Dimensions: LxWxH	270 x 115 x 110 mm	310 x 250 x 110 mm	385 x 560 x 110 mm	345 x 400 x 145 mm	415 x 1120 x 145 mm
Weight kg:	7.5 kg	16 kg	50 kg	40 kg	130 kg

Item No 1952057730



Item No 1952057730

2x12 24 TON



Item No 1952057728

2x6 TON



Item No 1952057726

2x3 TON



Item No 1951057706

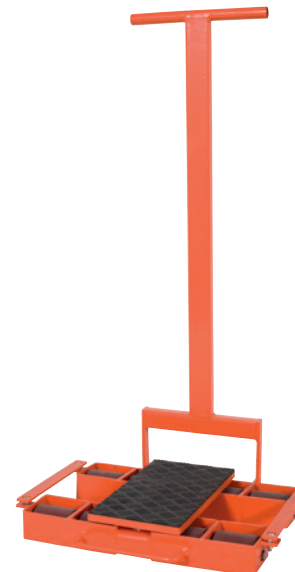

Item No 1951057704

Item No 1951057724





ENVIRONMENTAL HANDLING

DRUM LIFTER FL 300

The drum lifter is designed for handling of 200-litre drums. Automatically locks the drum during lifting. It can lift drums in and out of most transport vehicles. Simple lift with a foot pedal and lowering with a manually operated dead man's hand grip.

- Total height to maximum height for both lifters 1920 mm,
- Dimensions between support legs = 870 mm.
- Supplied unassembled.

Item No 1851054310



Item No	1851054300	1851054310
Identification	FL 300 A	FL 300 AH
Capacity kg	300	300
Lifting height mm	700	700
Fork wheel Ø mm	65 Nylon	125 Nylon
Steering wheel Ø mm	80 Nylon	125 Nylon
Weight kg	67	70

DRUM STACKER WITH TILT FUNCTION

The drum lifter is designed for lifting and tilting of 200-litre drums in both metal and plastic. Excellent tool for emptying and stacking drums. Safe and simple lifting with a foot pedal. The drum tilt is operated with a manually operated crank. Distance between support legs = 900 mm

Item No	1851054141
Identification	DA45
Capacity kg	450
Lifting height mm	1500
Fork wheel Ø mm	80x55 Nylon
Steering wheel Ø mm	150 Nylon
Weight kg	176
Total width mm	1000
Total height mm	2100
Total length mm	1400

Item No 1851054141

For plastic and metal drums



DRUM & TYRE TROLLEY

Drum trolley made of steel for handling of 200L drums, tyres or other loads with circular bottoms. Welded steel design. High stability. The trolley is equipped with 4 smaller wheels.

Item No	1915054000
Identification	DT-55
Capacity kg	300
Internal diameter Ø mm	598
Total height mm	157
Wheel Ø mm	75
Weight kg	9.5



Item No 1915054000



DRUM & TYRE TROLLEY

Drum trolley made of Polyethylene for 200 liter drums. The perfect tool for moving heavy oil drums in a simple and flexible way. The trolley is equipped with 5 smaller wheels.

Item No	1915054004
Identification	SD55E
Capacity kg	400
Internal diameter Ø mm	598
Total height mm	180
Wheel Ø mm	75
Weight kg	6.2



NEW

Item No 19150540004



DRUM LIFT

Barrel lift for easy and safe handling of barrels. The drum lift grips the drum by lowering the forks until the drum is in a horizontal position, the drum is then secured for transport to a shelf rack or a drum shelf for horizontal drums.

Item No	1222054430
Identification	DR400
Capacity kg	400
Total length mm	1900
Total width mm	690
Total height mm	655
Weight	75
Max fork size mm	140x50 mm

Item No 1222054430



NEW

DRUM CLAMP UNIT

Automatic clamping unit for all types of drums. The unit is mounted directly on to the truck's forks and is locked in place with wing nuts. When the drum is lifted, it is automatically locked in place by the unit's arms.

Item No	1222054401
Identification	DG40
Capacity kg	300
Total length mm	1070
Total width mm	700
RAL Colour	3020
Weight	60
Internal dimensions of the fork channels	178x58 mm



Item No 1222054401

DRUM GRIP

Safe and flexible drum tongs for horizontal lifting of 210-litre drums with rims or rings. Suitable for placing drums on drum pallets, stands, etc. Semiautomatic locking device. The grapples are locked in an open position and lowered down to the drum. Once they are subsequently released, they lock automatically under the rim during lifting. Capacity of 500 kg, weight of 5.2 kg.

DN 500
Item No 1222054405



DRUM CLAMP

Safe and flexible drum tongs for horizontal lifting of 210-litre drums with rims or rings. Fast and simple handling from cranes or trucks. Capacity of 350 kg, weight of 9.5 kg.

DL 350
Item No 1222054400



DRUM GRIP UNIT

Automatic clamping unit for lifting and transporting steel drums by truck. The unit is easily fitted to the truck's forks and locked in place with wing nuts. Automatically grips the drum and holds it securely in place during transport. The height of the device is adjustable to fit all sizes of steel drums. Available in versions for handling of 1 or 2 drums at the same time.



Item No 1222054420

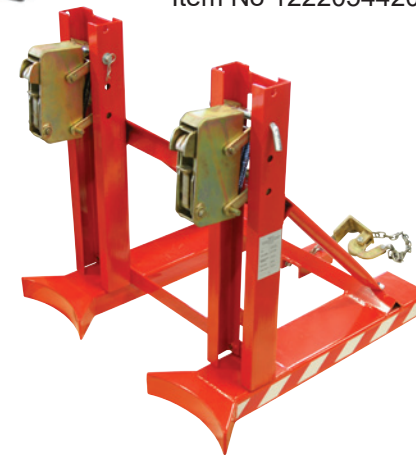

Item No	1222054410	1222054420
Identification	DG360A	DG720A
Capacity kg	360	720
Total length mm	850	850
Total width mm	670	910
Total height mm	930	930
RAL Colour	3020	3020
Weight	45	62
Internal dimensions of the fork pockets	150x55 mm	150x55 mm
Fork opening mm	500	590

Item No 1222054410



SPILL TRAY

Spill tray for a safe storage of chemicals in drums, jerry cans, bottles, etc. It can also be used to hold spare and machine parts during service of machinery and vehicles. Manoeuvred with hand trucks, stackers or forklifts.

Item No 2314021110

Item No	2314021110
Volume L	260
Height mm	350
Width mm	800
Length mm	1250
Weight kg	40



SPILL TRAY

Spill tray for a safe storage of chemicals in drums, jerry cans, bottles, etc. It can also be used to hold spare and machine parts during service of machinery and vehicles. Manoeuvred with hand trucks, stackers or forklifts.

Item No 2311020120

Item No	2311020120	2311020140
Volume L	260	380
Height mm	380	380
Width mm	1250	1250
Length mm	950	1250

NEW



Item No 2512022022

MESH FOR SPILL TRAY

Easily add this mesh to your spilltray for easier handling of your drums. Very easy installation when you simply put on the net frame which fits perfectly on the edges of the tray. No tools or screws needed.

Item No	2512022022	2512022023
Fits article	2311020120	2311020140
Height mm	45	45
Width mm	1240	1240
Length mm	940	1240

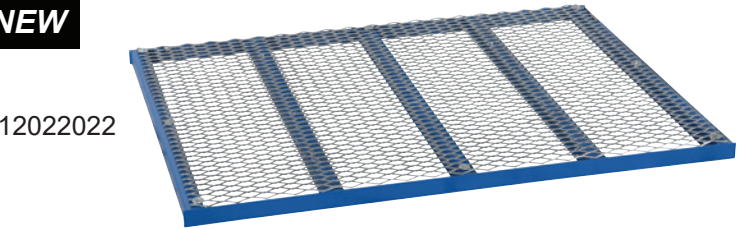

Item No 2311020120 + 2512022022

PALLET TRAYS

Pallet trays for a safe storage of chemicals in drums, jerry cans, bottles, etc. They can also be used to hold spare and machine parts during service of machinery and vehicles. The pallet trays are intended to be used together with Euro pallets.

Item No	2314021215	2314021240
Volume L	150	400
Height mm	160	415
Width mm	810	810
Length mm	1250	1250
Weight kg	24	38

Item No 2314021240

Item No 2314021215



OPEN DRUM PALLETS FOR STANDING DRUMS

Item No	2311020010	2311020020	2311020040
Volume L	220	260	380
Number of drums	1	2	4
Length mm	950	950	1250
Width mm	950	1250	1250
Height mm	350	300	300

Item No 2311020020



Trolley unit Item No 8611022040 contains a pushing handle and a wheel set in nylon.



DRUM PALLETS WITH SAFETY RAILING FOR STANDING DRUMS

Item No	2311020012	2311020022	2311020042
Volume L	220	260	440
Number of drums	1	2	4
Length mm	950	950	1250
Width mm	950	1200	1200
Height mm	910	910	910

ACCESSORIES: Wheel set:
(2 fixed wheels & 2 castors)

Choose between nylon 150 mm
or rubber 160 mm.

Wheel set/nylon = Item No 8611019030

Wheel set/rubber = Item No 8612019031

Item No 2311020022



DRUM PALLETS FOR LAYING DRUMS

Item No	2311021010	2311021020	2311021022
Volume L	260	440	440
Number of drums	1	2	4
Length mm	950	1550	1550
Width mm	1250	1250	1250
Height mm	580	580	1280

Item No 2311021010

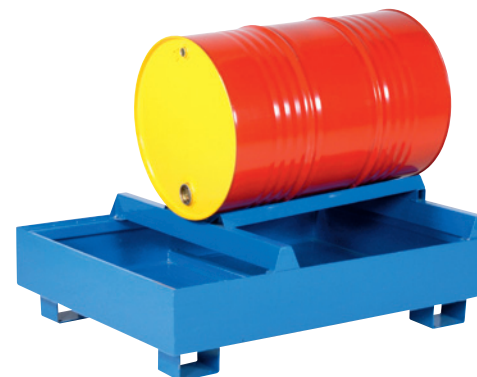

Item No 2311021022

ACCESSORIES: Wheel set:
(2 fixed wheels & 2 castors)

Choose between nylon 150 mm
or rubber 160 mm.

Wheel set/nylon = Item No 8611019030

Wheel set/rubber = Item No 8612019031

ENCLOSED DRUM PALLETS FOR STANDING DRUMS

Item No	2311020013	2311020023	2311020043
Volume L	220	260	380
Number of drums	1	2	4
Length mm	950	950	1250
Width mm	950	1280	1280
Height mm	1330	1330	1330

Item No 2311020023



ACCESSORIES: Wheel set:
(2 fixed wheels & 2 castors)

Choose between nylon 150 mm
or rubber 160 mm.

Wheel set/nylon = Item No 8611019030

Wheel set/rubber = Item No 8612019031

DRUM PALLETS FOR 1 OR 2 CIPAX CONTAINERS

Item No	2311021101	2311021102
Volume L	1100	1200
Number of drums	1	2
Length mm	1310	2530
Width mm	1310	1310
Height mm	750	450

Item No
2311021101



Item No 2311021102



ACCESSORIES: Wheel set:
(2 fixed wheels & 2 castors)

Choose between nylon 150 mm
or rubber 160 mm.

Wheel set/nylon = Item No 8611019030

Wheel set/rubber = Item No 8612019031

TOOL STORAGE

Robust tool storage for secure storage of tools on building sites, etc. Also suitable for use as a worktable. Powder coated. Lockable with padlock.

Stackable with safety edge.

Item No 2018017075



Item No 2018017076



Item No	2018017075	2018017076
Identification	Tool Box w. front lid	Tool Box w. Doors
Capacity kg	600	600
Length mm	845	845
Width mm	1230	1230
Height mm	956	956
Weight kg	150	150

BOTTOM DISCHARGING CONTAINERS

Always easy to empty as the whole bottom opens. Automatic opening and locking after emptying. It should be emptied by a forklift truck or a stacking truck. It can be moved with most forklift trucks and fork lifting devices available on the market.

Powder coated.
Stackable.
Also available with a factoryfitted cover.



QR-code
Link to
instruction
video

Item No 2017018100



Item No	2017018070	2017018100	2017018180
Identification	BTC 07	BTC 10	BTC 18
Capacity kg	800	800	800
Volume L	700	1000	1800
Length mm	800	900	1000
Width mm	1200	1200	1600
Height mm	900	1100	1300
Weight kg	115	149	224

ACCESSORY FLAT LID (FACTORY FITTED)

Item No	2511018079	2511018109	2511018189
Fitted to	18070 (BTC 07)	18100 (BTC 10)	18180 (BTC 18)

TOOL TROLLEY

Robust tool trolley for secure storage of tools on building sites, etc. Strong lock with 3 locking points. Equipped with four solid rubber wheels, two of which are equipped with brakes, 160 mm in diameter. Also suitable for use as a worktable. Powder coated. Lockable with padlock.

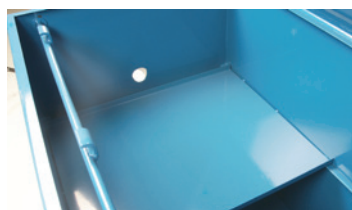

Including a movable shelf
and a hole for cables.



Item No
2018017040

Item No	2018017040
Size LxWxH	1100x660x870
Max load kg	600
Wheel Ø mm solid rubber	160
Weight kg	63

BOTTOM DISCHARGING CONTAINERS

Always easy to empty as the whole bottom opens. Automatic opening and locking after emptying. It should be emptied by a forklift truck or a stacking truck. It can be moved with most forklift trucks and fork lifting devices available on the market.

Powder coated.
Stackable.

NEW

Item No 2017018101



Item No	2017018071	2017018101	2017018181
Identification	BTC DB-07	BTC DB-10	BTC DB-18
Capacity kg	1000	1000	1000
Volume L	700	1000	1800
Length mm	750	1000	1000
Width mm	1200	1200	1600
Height mm	1100	1100	1300
Weight kg	108,5	125	224



120 L

360 L

120 L

240 L

REFUSE BINS

Volume L	120	240	360
Width mm	460	570	700
Height mm	950	1000	1100
Depth mm	550	740	850
Steering wheel mm	200x50	200x50	200x50
Capacity kg	60	120	160
Colour	Grey	Grey	Grey

REFUSE BINS 120 L

Item No	2112031102	2112031103	2112031106	2112031107
Colour	Green	Red	Blue	Grey

REFUSE BINS 240 L

Item No	2124031202	2124031203	2124031206	2124031207
Colour	Green	Red	Blue	Grey

REFUSE BINS 360 L

Item No	2136031302	2136031303	2136031306	2136031307
Colour	Green	Red	Blue	Grey

BIN DISCHARGER FOR FORKLIFT TRUCKS

For simple and flexible emptying of refuse bins. Suitable for plastic bins from 40 to 400 litres. Distance between fork tunnels of 760 mm, Fork tunnel width of 180 mm. Total width of 1120 mm. Total length of 1430 mm (incl. hooks). Powder coated. Blue RAL 5019.

Item No	1224031000
Fork tunnel distance mm	760
Fork tunnel width mm	180
Total width mm	1120
Total length mm (incl. hooks)	1430
Suitable for bins of between	40 and 400 Litres
Weight kg	39



Item No 1224031000



LIGHT TILTING SKIPS

Tilting skips for lighter waste sorting, waste and material handling. Designed, reinforced and powder coated to provide maximum safety and service life. Spring pressure plate on the base frame for automatic emptying. Also with manual tipping. The stop lug is well dimensioned in order to deal with the forces it can be exposed to. The automatic tipping function does not only provide greater efficiency, it also raises safety during emptying at greater heights as the tilting skip cannot slide from the forks. RAL 5005.



Item No 2019050090



NEW

Item No	2019050030	2019050060	2019050090	2019050110	2019050160
Identification	Tippo Light 300	Tippo Light 600	Tippo Light 900	Tippo Light 1100	Tippo Light 1600
Volume cubic	0.3	0.6	0.9	1.1	1.6
Volume litre	260	520	765	1030	1340
Length mm	1240	1520	1524	1702	2073
Width mm	840	860	1210	1215	1065
Total Height mm	757	867	871	1045	1242
Weight kg	66,5	78,5	89	113	135
Steel plate mm	1,2	1,2	1,2	1,2	1,2
Capacity kg	600	600	600	600	600

Sizes from 300 litres up to and including 1600 litres have the following base frame dimensions: A=160 mm, B=220 mm, C=615 mm, D=110 mm.

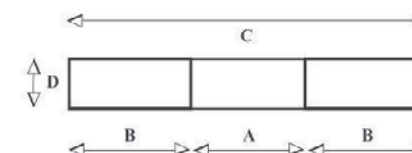

STANDARD TILTING SKIPS

- Tilting skips are the industry's best tool for waste assorting and material handling.
- Designed, reinforced and powder coated to provide maximum safety and service life.
- Spring pressure plate on the base frame for automatic tilting.
- Also with manual tipping.
- Other sizes are manufactured on request.

TIPPO have reinforcements in the right places in order to deal with rough handling.

- Corner reinforcements improves the stiffness of the containers.
- Reinforced fork channels.
- The stop lug is well dimensioned in order to deal with the forces it can be exposed to.
- The automatic tipping function does not only provide greater efficiency, it also raises safety during emptying at greater heights as TIPPO cannot slide from the forks.



QR-code
Link to
instruction
video

CHOOSEABLE COLORS FOR ALL TILTING SKIPS

	BLUE	= Paper	Color no: (RAL 5019)
	RED	= Environmentally hazardous	Color no: (RAL 3020)
	WHITE	= Plastic	Color no: (RAL 9010)
	ORANGE	= Flammable	Color no: (RAL 2008)
	YELLOW	= Textile	Color no: (RAL 1021)
	BROWN	= Compostable	Color no: (RAL 8017)
	GREEN	= Glass	Color no: (RAL 6032)
	GREY	= Metal	Color no: (RAL 7042)
	Black		Color no: (RAL 9005)

Tilting skips are exceptionally suited for waste assorting. They can be supplied in colours as recommended by the public waste collection service or to suite your need.



Item No 2011010-	015	030	060	090	110	160	200	250	300
Identification	Tippo 150	Tippo 300	Tippo 600	Tippo 900	Tippo 1100	Tippo 1600	Tippo 2000	Tippo 2500	Tippo 3000
Volume cubic	0.15	0.3	0.6	0.9	1.1	1.6	2.0	2.5	3.0
Volume litre	130	260	520	765	1030	1340	1700	2050	2500
Length mm	815	1235	1525	1525	1700	2073	2073	2073	2073
Width mm	760	840	865	1215	1215	1066	1316	1566	1866
Height mm	580	750	870	870	1045	1248	1248	1248	1248
Weight kg	55	80	101	122	157	205	253	288	321
Steel plate mm	2	2	2	2 / 2,5	2 / 2,5	2,5	2,5	2,5	2,5
Capacity kg	1200	1500	2000	2000	2000	2000	2000	2000	2000

Sizes from 150 litres up to and including 1600 litres have the following base frame dimensions:
A=160 mm, B=230 mm, C=630 mm, D=100 mm.
Sizes from 2000 litres up to and including 3000 litres have the following base frame dimensions:
A=560 mm, B=230 mm, C=1035 mm, D=100 mm.

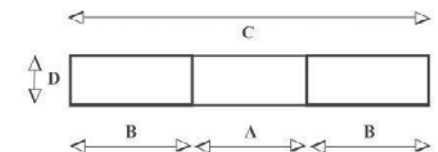

HEAVY DUTY TILTING SKIPS

Tippo HD, a heavy duty tilting skip for heavier materials and rougher handling. 3 mm steel plate and reinforcements at sensitive locations ensures strength. Lower front for easier control of the material when emptying. Longer and higher handle for manual emptying makes it easier for the user. Automatic emptying with the pressure plate on front edge of the chassis allows the driver to safely sit in the fork lift truck throughout the tilting procedure and thereby minimize the risk of accidents. Wire holding container to the undercarriage for involuntary discharge not to occur. The same cable also works as a fork lock and pulled around the truck stand before emptying to take place and prevents the container from being able to slip of the forks.

Item No 2015141600

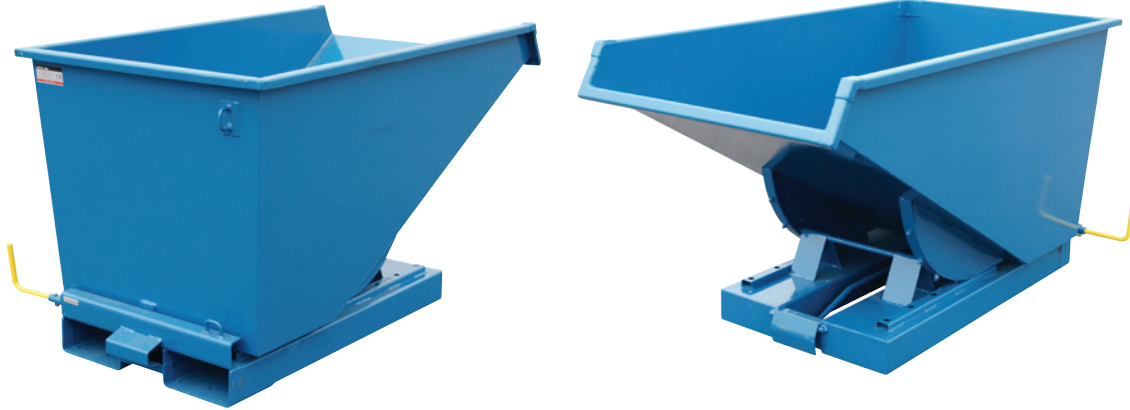

Item No	2015140300	2015140600	2015140900	2015141100	2015141600
Identification	Tippo HD 300	Tippo HD 600	Tippo HD 900	Tippo HD 1100	Tippo HD 1600
Volume cubic	0.3	0.6	0.9	1.1	1.6
Length mm	1230	1540	1540	1860	2150
Width mm	840	870	1215	1215	1065
Total Height mm	760	875	875	1045	1245
Height in front mm	635	770	770	885	1035
Weight kg	110	135	159	188	235
Steel plate mm	3	3	3	3	3
Capacity kg	2500	2500	2500	2500	2500

Sizes from 300 litres up to and including 1600 litres have the following base frame dimensions: A=160 mm, B=220 mm, C=615 mm, D=110 mm.

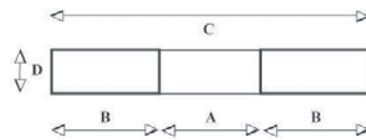

TILTING SKIPS STAINLESS STEEL #304

Tilting skips in stainless steel grade 304 for use within material- and waste handling in harsh environments and in the food industry. Can also be equipped with a nylon wheel set with steel parts in grade 304, article number 8611019032.



Item No	2019020038	2019020068	2019020098
Identification	LTS 30	LTS 60	LTS 90
Volume cubic	0.3	0.6	0.9
Volume Litre	320	520	765
Length mm	1235	1525	1525
Width mm	840	865	1215
Height mm	750	870	870
Weight kg	80	101	122
Capacity kg	1500	2000	2000

Frame dimensions:
A=160 mm, B=220 mm,
C=615 mm, D=110 mm.

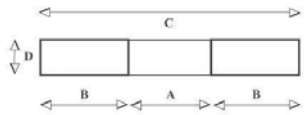

TILTING SKIPS WITH HIGH COVER

Item No 201211110

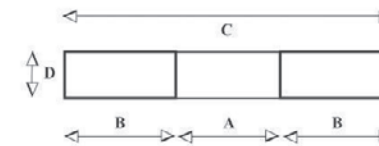

Sizes from 200 litres up to and including 1700 litres have the following base frame dimensions: A=160 mm, B=230 mm, C=630 mm, D=100 mm.
Sizes from 2200 litres up to and including 2700 litres have the following base frame dimensions: A=560 mm, B=230 mm, C=1035 mm, D=100 mm.



Item No	2012011020	2012011040	2012011075	2012011110	2012011130	2012011170	2012011220	2012011270
Identification	TL 200	TL 400	TL 750	TL 1100	TL 1300	TL 1700	TL 220	TL 2700
Volume cubic	0.2	0.4	0.75	1.1	1.3	1.7	2.2	2.7
Volume Litre	130	320	520	770	1030	1350	1700	2050
Length mm	815	1235	1525	1525	1700	2073	2073	2073
Width mm	780	860	880	1230	1230	1080	1330	1580
Height mm	900	1110	1295	1295	1545	1845	1845	1845
Weight kg	90	140	175	240	260	330	350	430
Capacity Kg	1200	1500	2000	2000	2000	2000	2000	2000
Number of doors	1	1	1	2	2	1	2	2

ACCESSORIES: FLAT COVER TO OPEN TILTING SKIPS. CAN EASILY BE RETROFITTED.

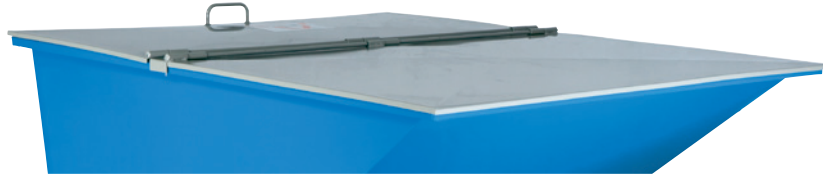

Item No	2511012021	2511012041	2511012076	2511012111	2511012131	2511012171	2511012221	2511012271	2511012301
Flat cover for	Tippo 150	Tippo 300	Tippo 600	Tippo 900	Tippo 1100	Tippo 1600	Tippo 2000	Tippo 2500	Tippo 3000

Safety chain Fork lock Distance heels Wheel set with spacers



Forkspreading



Net - crane – tight welding for liquid separation

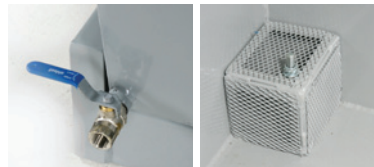

ACCESSORIES FOR TILTING SKIPS

Item No	2011010925	2512019040	2512019041	2512019042	2512019044	2512019046
Identification	Safety chain	Fork lock	Spacer heels for handling with stacking trucks	Spacer heels for wheels when handling with stacking trucks	Forkspreading for tilting the skip by spreading the forks	Net - crane – tight welding for liquid separation

WHEEL SETS FOR TILTING SKIPS

8611019030	8611019051	8612019031	8612017160	8612019037	8612019038	8611019032
Wheel set nylon 150 mm	Wheel set nylon 150 mm with break	Wheel set solid rubber 160 mm	Wheel set solid rubber 160 mm with break	Wheel set polyretan 160 mm	Wheel set polyretan 160 mm with break	Wheel set stainless steel 160 mm

Item No 8611019030 Item No 8612019031 Item No 8612019037 Item No 8611019032



TILTING SKIP TV300

Smooth tipper on wheels that can be rolled by hand or moved by a forklift. This tipper is made of sturdy powder-coated metal with an edge reinforced container to withstand a lot of hard and heavy use. Its low front makes it perfect to fit in under machines for gods or waste collection. The tipper has two wheels in front and a rear wheel with break as well as fork tunnels to be transported using a forklift.

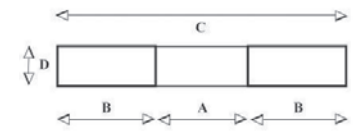

Fork channel dimensions
A=365 mm, B=165 mm,
C=700 mm, D=80 mm.

Item No	2014014030
Volume L	300
Capacity kg	300
Length mm	1200
Width mm	900
Height mm	1060



LOW TILTING SKIPS

Low containers are suitable for use in workstations where the height plays a role. They facilitate the handling of waste, sawdust, wood, splinters, etc. Built-in fork locking for safe handling. The low container has a low construction height and is thereby emptied over its axle using a strong hinge. Equipped with a spring pressure plate on the base frame for automatic emptying. Powder coated.

Item No	2013013055	2013013075	2013013090
Identification	Tippo LB 55	Tippo LB 75	Tippo LB 90
Capacity Kg	1500	1500	1500
Volume L	550	750	900
Length mm	1645	1645	1645
Width mm	1065	1315	1565
Height mm	525	525	525
Weight kg	116	129	142

Fork channel dimensions
A=150 mm, B=265 mm,
C=705 mm, D=95 mm.

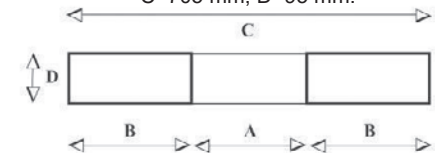

Item No 2013013055





PLOUGH FOR FORKLIFT TRUCKS

Plough with rubber that is exchangeable. Simple and easy to change in three positions and the fork channels have fork lock. The exchangeable rubber makes the snow plough last longer.

Item No 7012016520

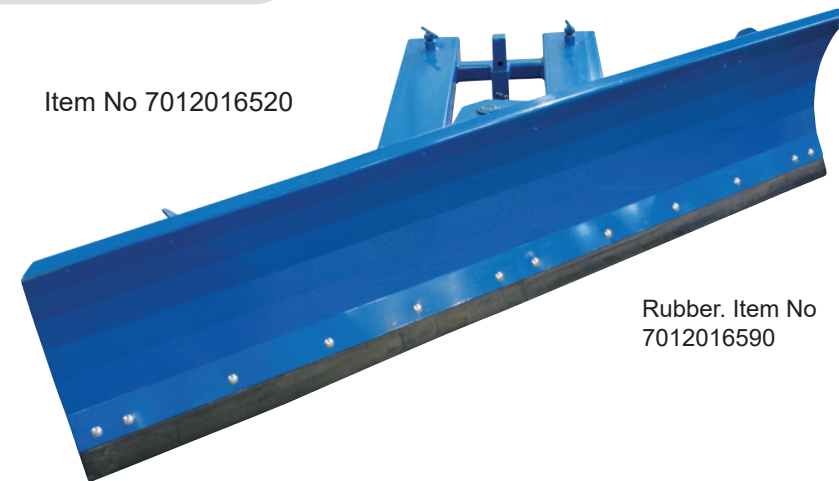

Rubber. Item No 7012016590



OUTDOOR PRODUCTS

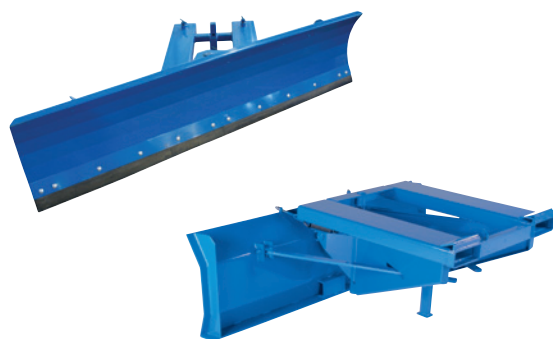

Item No	7012016520
Identification	SPR 20
Width mm	2000
Height blade mm	450
Weight	72

Fork channel internal dimensions:
A=250 mm, B=150 mm, C=570 mm, D=80 mm.

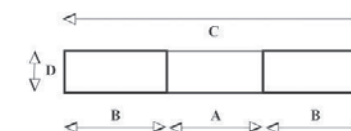

PLOUGHS FOR FORKLIFT TRUCKS

Strong ploughs in 8 mm sheet steel fitted with a spring mechanism and a fork lock for safe and effective ploughing. The spring mechanism causes the plough to retract in the event of a collision. Simple and easy adjustment to the truck's forks. Reinforced on the front edge for a long service life. The plough is adjustable in three positions: Right, left and straight. Powder coated.

Item No 7012016015

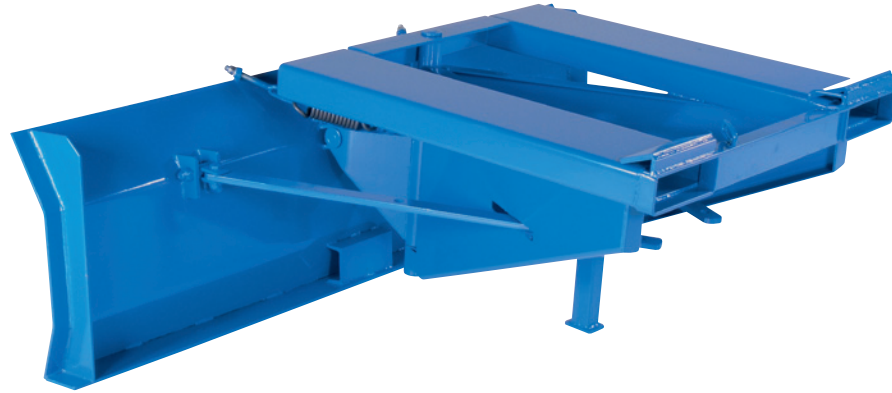

Item No	7012016015	7012016020	7012016025	7012016030
Identification	SP 15	SP 20	SP 25	SP 30
Width mm	1500	2000	2500	3000
Height blade mm	600	600	600	600
Weight	240	255	270	285

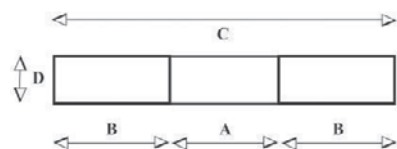

Fork channel internal dimensions:
A=525 mm, B=215 mm, C=975 mm, D=68 mm.

PLOUGH FOR FORKLIFT TRUCKS

Strong plough in 5 mm steel plate. Equipped with fork lock for safe and efficient plowing. Easy and fast bucking on your forks. Reinforced bottom for durability. The plow is solid and built for plowing side and is reversible for side plowing on the left and the right. Powder coated.

Item No 7012016518

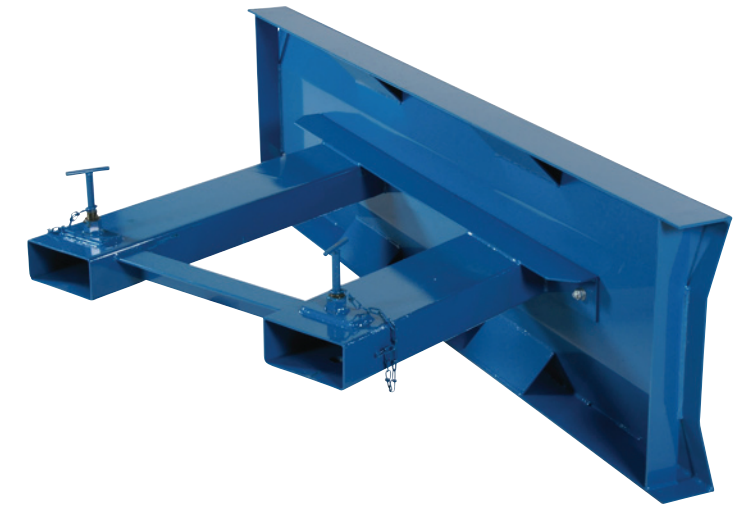

Item No	7012016518
Identification	SPF 18
Width mm	1800
Height blade mm	400
Weight	95

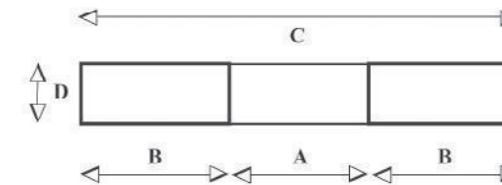

Fork channel internal dimensions:
A=430 mm, B=170 mm, C=790 mm, D=75 mm.

SNOW AND SAND SCOOP

Powerful truck scoop for handling and clearing of snow, gravel, sawdust, waste, etc. Manufactured in 3 mm sheet metal with strong hardwearing steel on the front edge. Built in fork locking for safe operation. Possible to get with forkspreading to tilt and empty the skip. Add forkspreading with art no 2512019044. Powder coated.

Item No 7011015015



Item No	7011015010	7011015015
Identification	SK 1	SK 2
Volume L	1000	1500
Length mm	1795	1795
Width mm	1500	2000
Height mm	600	750
Capacity Kg	1500	1500
Weight kg	154	209

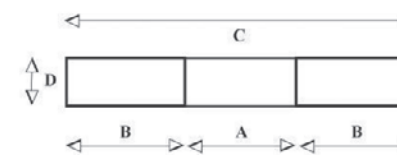

Fork channel dimensions
A=475 mm, B=265 mm, C=1025 mm, D=95 mm.



BICYCLE RACKS

Steady and stable bicycle rack for both wall and flat ground use.

- Galvanized frames.
- Location Distance c / c 320 mm.



Item No 2412001005



Item No	2412001003	2412001005
Identification	Bicycle rack short	Bicycle rack long
Bikes pcs	3	5
Height mm	260	260
Length mm	730	1340
Depth mm	330	330
Own weight kg	5	9

Visit our homepage - intra.se

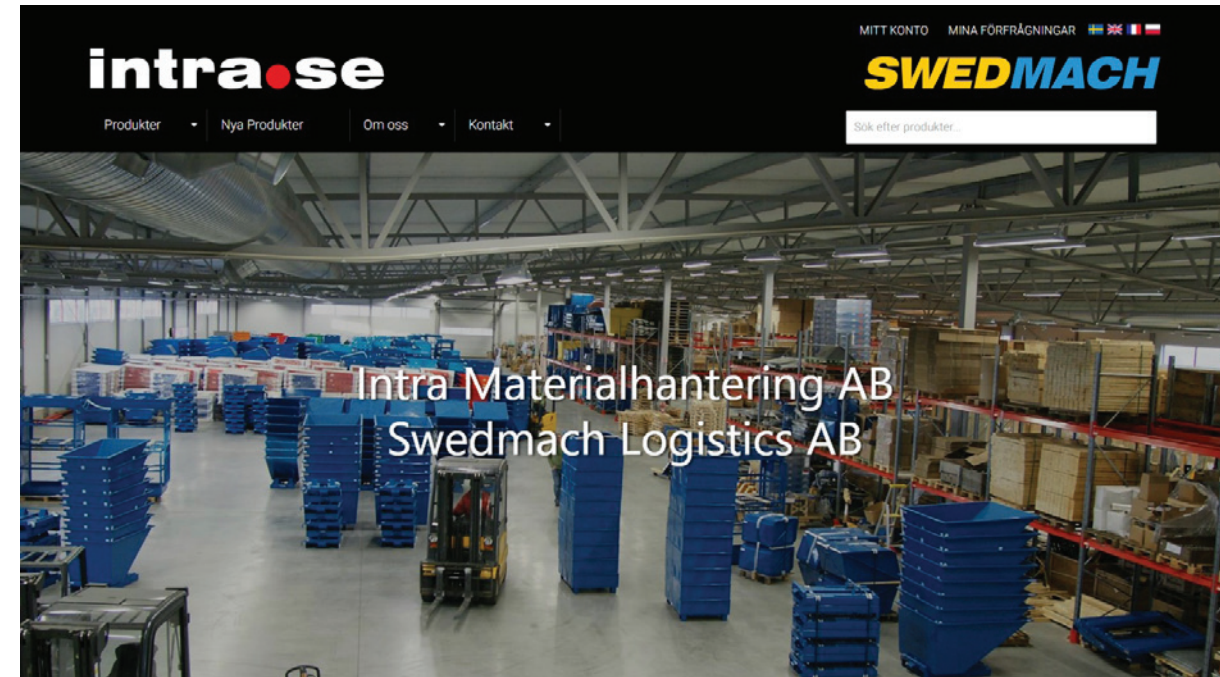

EFEKT - SNOW SHOVEL

With smart patented solutions, ergonomic and awarded for its design. EFEKT is the best and smartest solution for snow handling.

Item No 7025020086



Item No	7025020086
Identification	Shovel EFEKT
Blade width mm	370
Blade height mm	570
Overall height mm	1610
Thickness shaft mm	36

SALT & SAND CARRIER

Extra wide carrier for salt, sand and grain, etc. Long service life and stable design. Collapsible support; the length of the handle is adjustable. Pneumatic rubber wheel adapted for winter weather conditions and terrains. The flow can easily be adjusted to the desired amount. Plastic cover to keep sand and salt dry.

Item No 1970057150

Item No	1970057150
Total width mm	800
Width mm	600
Wheel type	Pneumatic
Wheel diameter mm	300
Volume L	35
Weight kg	16.5



You can find all the latest product news and updated product information on our homepage. You can get your own login so you can see updated prices, live stock balance and incoming deliveries. Contact us for more information!

intra●se

SWEDMACH

Intra AB & Swedmach AB
Truckvägen 2
SE-231 62 Trelleborg
Sweden
office@intra.se
phone +46 41062740

Intra Material Handling OU
Ravila 51
51014 Tartu
Estonia
office@intra-baltic.eu
phone +37 27447740



Swedmach France
77 Rue de Monswiller
67700 Saverne
France
office@swedmach.se
phone +33 388019528

Swedmach Sp z o.o
ul. Do Studzienki 63/6
80-227 Gdańsk
Poland
biuro@swedmach.pl
phone +48 727897000

Swedmach Slovenia
Cesta 4. maja 1880-227
1380 Cerknica
Slovenia
prodaja1@pamvilicar.si
phone +386 41 506 470